

EME 150A Fall 2015 Homework #03

Date: Monday, October 12, 2015

DUE: Monday, October 19, 2015 before class in Box D in the MAE department.

Problem 1

What is the maximum force F that can be applied to this system to ensure that the stress in member CD never exceeds 20 kpsi and the point A moves no more than 0.05"? Assume that the curved bar, ABC , is much more rigid than CD , i.e. assume it doesn't deform. The modulus of elasticity of the bar CD is $6 \times 10^6 \frac{\text{lb}}{\text{in}^2}$ and the cross sectional area is 0.25in^2 . All of the joints are pin joints.

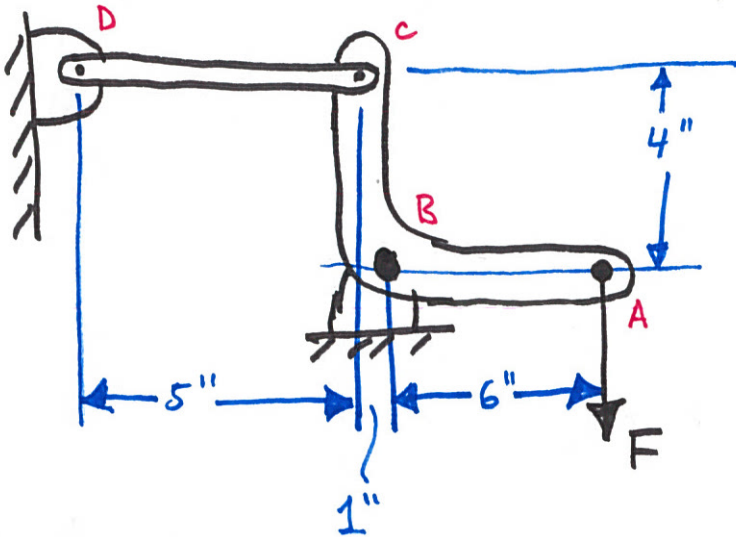

Problem 2

Three strain gauges are arranged in the orientation shown below on a free surface of a stressed member. The measured strains from the strain gauges are:

- $\epsilon_A = 50 \times 10^{-6}$
- $\epsilon_B = 120 \times 10^{-6}$
- $\epsilon_C = 264 \times 10^{-6}$

- Derive the symbolic expressions for $\epsilon_x, \epsilon_y, \epsilon_z$ for this configuration. Use only rational numbers, i.e. no decimal numbers and compute the state of strain.
- Find the principal strains and directions.
- If $E = 106 \text{GPa}$ and $G = 40 \text{GPa}$, what are the principal stresses and directions? Keep in mind that the normal stress on the surface is 0 because it is a free surface.

d. What is the maximum principal shear stress?

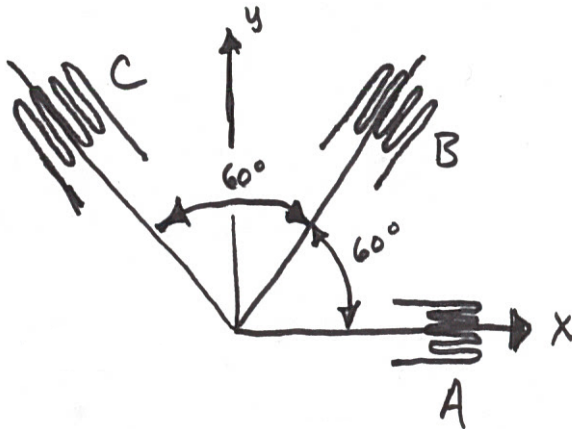

Problem 3

Find the maximum stress in the axially loaded member shown below. The hole is far enough away from the step down that the stress concentrations do not interact.

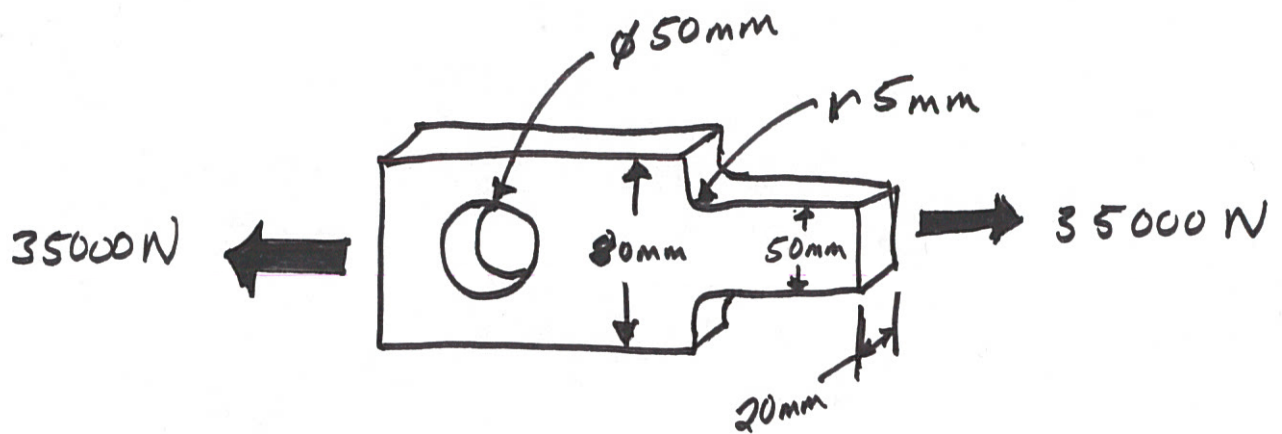

Problem 4

A rock climbing carabiner is shown below. The carabiner must be able to withstand a force up to 2700 lb to be safe enough to catch a 10 ft fall. What are the curved beam theory predicted stresses at the inner and outer points on section A-A? The cross section is circular.

