

WHIM Wheelchair

A DIY Electric Powered Wheelchair

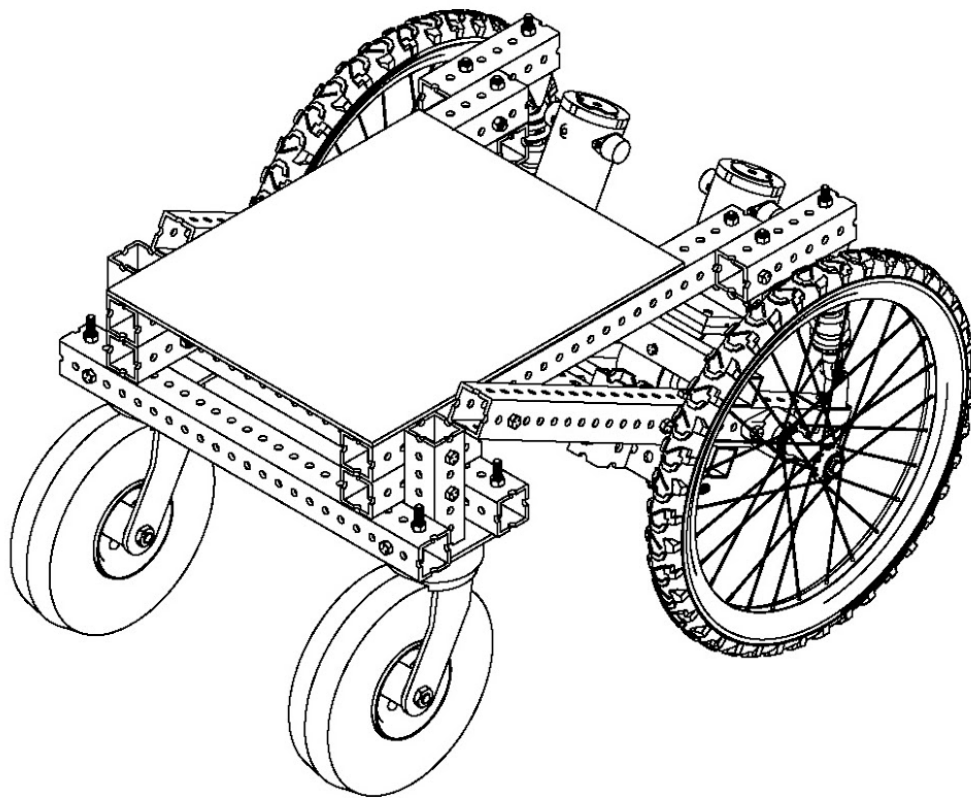

Created for EME185 - Senior Design at UC Davis

Group Members: [REDACTED]

Sponsors: [REDACTED]

Foreward

The assembly guide that follows was put together by a group of three UC Davis Mechanical Engineering students as part of our Senior Design Project. The goal of the project was to prove someone could build their own electric powered wheelchair in their garage using basic tools such as a chop saw and drill press. The scope of our project included producing a working drive-train and frame that would provide a solid foundation for our sponsors, WHIM Unlimited, to develop a fully working and refined electric powered wheelchair. We hope this assembly guide will provide the necessary framework for others to build their own chair, ending the longtime dependence on inconvenient health and insurance companies. This guide is by no means includes a final product, but rather a proof of concept and a framework for others to build off of to fit their own personal mobility needs. For more information, please visit whimunlimited.com.

We wish you the best of luck in building your own chair and hope you have as much fun as we did.

Sincerely,



Chair Dimensions

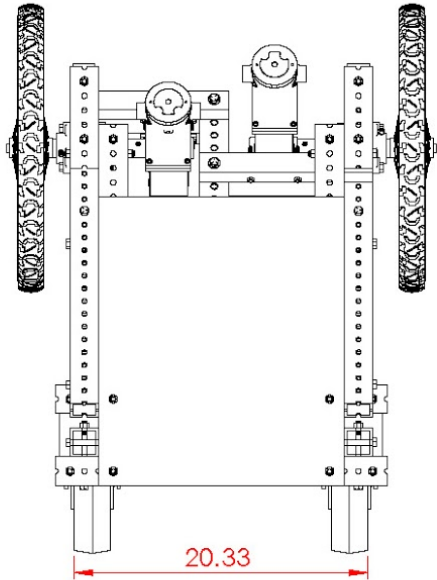

NOTE: Although the chair's dimensions (length of ~40" by width of ~30") are within ADA standards, we've determined the width is a large by about 3" to 4". This is addressed in section 5.0 on page 28.

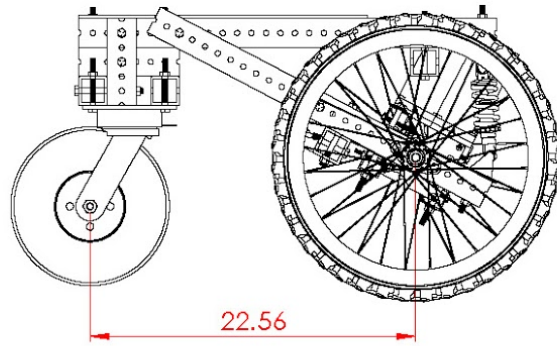
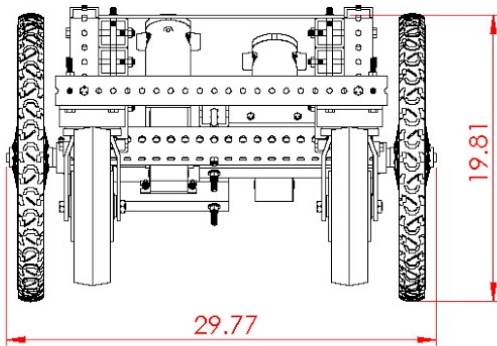

Table of Contents

Section	Page	
1.0	Bill of Materials	1
	Bolt Guide	2
2.0	Alternate Parts List	3
3.0	Cut Sheets	4
	Custom Parts Guide	4
	Tools Used	5
	Custom Part Drawings	6
4.0	Assembly	12
4.1	Caster Assembly	12
4.2	Motor Assembly	13
4.3	Final Assembly	23
5.0	Design Recommendations	28
	Add-ons and Accessories	29
	Battery Suggestions	30
	Controller Suggestions	30
6.0	Maintenance Guide	31

NOTE: Make sure to read all of the assembly guide before starting to build. The chair in the guide is ~4" too wide, so its mobility may be limited in some areas. For more informations, see section 5.0.

1.0 Bill of Materials

Part Name	Qty	URL	Price
20" BMX Wheel	2	http://www.ebay.com/itm/20-BMX-MAG-Plastic-6-spokes-Front-Rear-Freewheel-wheel-Black-/331622862142	\$110
10" Caster Wheel	2	http://www.mcmaster.com/#22925t34/=1279wuu	\$110
8' Gridbeam Stock	3	http://www.mcmaster.com/#6535k292/=12703zc	\$200
24V Battery (total)	2	http://www.amazon.com/D5751-UB121100-GROUP-27-TERMINALS/dp/B005ENCT3O	\$400
24V DC Brushed Motor	2	https://www.zoro.com/dayton-dc-gear-motor-rpm-150-24vdc-Slag5/HG0897757/	\$800
5/8" Axle (3 ft., needs machining)	1	http://www.amazon.com/Stanley-National-Hardware-4005-BC-Plated/dp/B0029T9ALA/ref=pb_sbs_328_1?ie=UTF8&dpID=311gfs:QBwRL&dpSrc=sims&preST=_AC_UL160_SRL160%2C160_&refRID=1YWQWZMGFN2HVRA25AC3	\$16
Coupling	2	http://www.amazon.com/Hub-City-FE260URX5-Setscrew-Mounting/dp/B00ECZTC7Q/ref=sr_1_1?ie=UTF8&qid=1457801899&sr=1-1&keywords=mount%20bearings&refinements=p_bore_Size_derived-vebin%3A0.625%20inches	\$25
Mounted Bearing	4	http://www.amazon.com/Hub-City-FE260URX5-Setscrew-Mounting/dp/B00ECZTC7Q/ref=sr_1_1?ie=UTF8&qid=1457801899&sr=1-1&keywords=mount%20bearings&refinements=p_bore_Size_derived-vebin%3A0.625%20inches	\$80
1.5"x1.5" Square Tubing (4ft. needs machining)	1	http://www.onlinemetals.com/merchant.cfm?pid=10322&step=4&show-units=inches&id=845&top_cat=849	\$10
Chair Shelf (0.75" plywood)	1	http://www.homedepot.com/p/Sanded-Plywood-Common-23-32-in-x-2-ft-x-2-ft-Actual-0-703-in-x-23-75-in-x-23-75-in-1502014/202089017	\$9
Bike Shock	2	http://www.ebay.com/itm/Rear-Suspension-Damper-Spring-Shock-Absorber-650LBS-IN-Bike-Mountain-Bicycle-/381229235482?hash=item58c3087d1a:g:K3oAAOSwBahVMIT3	\$20
Motor H bridge Controller (Arduino based)	2	http://www.amazon.com/MegaMoto-Motor-Control-Shield-Arduino/dp/B00R5CCU90/ref=sr_1_1?ie=UTF8&qid=1461990777&sr=8-1&keywords=megamoto+arduino	\$120
Bike Shock Mounts	4	http://www.homedepot.com/p/Richelieu-Hardware-2-in-General-Duty-Rubber-Rigid-Caster-F25748/204695835	\$9
1/4" thick (1' x 1' A36 Steel Plate) (needs machining)	1	http://www.metalsdepot.com/products/hrsteel2.phtml?page=plate&LimAcc=%20&id=	\$22
3/8" x 6.5" bolt (10 pack)	1	http://www.mcmaster.com/#91247A649	\$10
3/8" x 4.5" bolt (10 pack)	3	http://www.mcmaster.com/#91247A642	\$21
3/8" x 3.5" bolt (10 pack)	1	http://www.mcmaster.com/#92865A638	\$8
3/8" x 3" bolt (25 pack)	1	http://www.mcmaster.com/#91247A636	\$11
3/8" x 7" bolt (5 pack)	1	http://www.mcmaster.com/#91247A650	\$7
1/4" x 2.5" bolt (25 pack)	1	http://www.mcmaster.com/#92865A552	\$8
3/8" hex nut (100 pack)	1	http://www.mcmaster.com/#95462A031	\$8
1/4" hex nut (100 pack)	1	http://www.mcmaster.com/#95462A029	\$5
6-32 bolt (0.75") (100 pack)	1	http://www.mcmaster.com/#91251a151/=12k3aqd	\$9
6-32 locknut (100 pack)	1	http://www.mcmaster.com/#90633a007/=12k3bxw	\$3
3/8" Flat Washers (100 pack)	1	http://www.mcmaster.com/#92141A031	\$6
3/8" Lock Washer (100 pack)	1	http://www.mcmaster.com/#92146A031	\$9
12" Keyway stock	1	http://www.amazon.com/dp/B0035EZTSO/ref=biss_dp_t_asn	\$4
Total			\$2,040

NOTE: All parts listed are based on those used in the following prototype and are meant to be a guideline for following this guide.

Bolts Guide

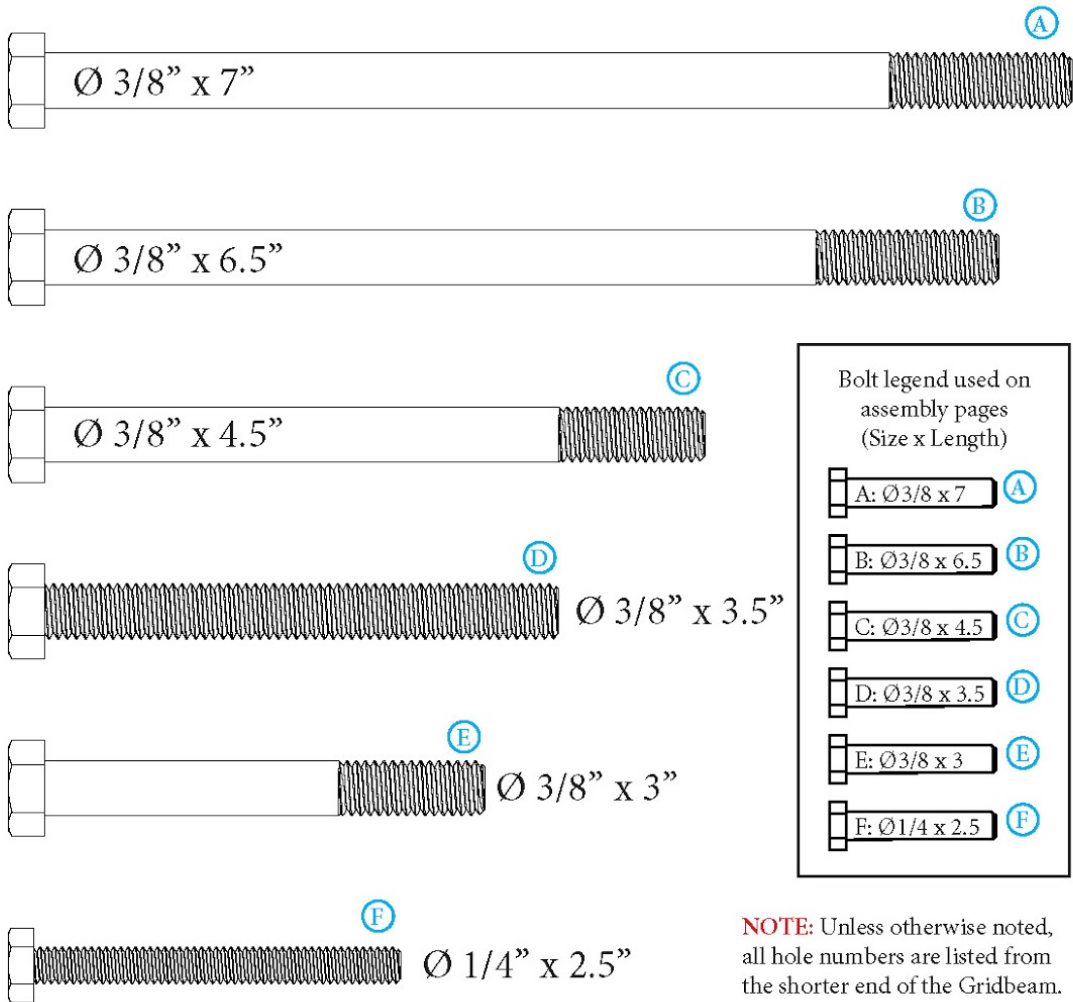

2.0 Alternate Parts

Part Name	Qty	URL	Price
2"x2" Gridbeam	1	http://www.unistrutohio.com/telespar-telescoping-square-tubing/	Call
2"x2" Gridbeam (6ft)	1	http://www.mcmaster.com/#6535k292/=12703zc	\$50
2"x2" Gridbeam (8ft)	3	http://www.eberliron.com/1407/detail/category/1240.html	\$115
	3	http://www.exercise-equipment-parts.com/2-inch-telescopic-tube-galvanized-holes.html	\$180
	1	http://www.allmetalsinc.com/pt2002000747.html	\$90
24V DC Brushed Motor	2	http://www.automationdirect.com/ad/Shopping/Catalog/Motors/DC_Gearmotors_-_IronHorse_%28up_to_.25HP%29/24_VDC_Right_Angle_Gearmotors/MTGR-P20-1K075	\$560
	2	http://www.kimcontrols.com/item/MTGRP201K174 (Only sells to people located in the Upper Midwest)	\$560
	2	http://www.electricmotorwarehouse.com/dayton-24-volt-dc-right-angle-gear-motor-1-8-hp-150-rpm-5lag5/#sthash.VAj7SKLi.dpbs	\$800
	2	http://www.amazon.com/Dayton-Right-Angle-Gear-Motor/dp/B00WO6G36S	\$800
	2	http://www.walmart.com/ip/DAYTON-5LAG5-DC-Gearmotor-RPM-150-24VDC/41970771	\$800
	2	https://www.grainger.com/product/DAYTON-DC-Gearmotor-24VDC-Nameplate-5LAG5?searchBar=true&searchQuery=5lag5	\$960
24V (total) Battery	2	https://www.batterystuff.com/batteries/ups-telecom/UB12110-45824.html	\$535
	2	https://www.1000bulbs.com/product/56373/BAT-UB121100FL1.html	\$400
5/8" x 2' Axle (needs machining)	1	http://www.mcmaster.com/#1346k25/=11bykgk	\$20
Coupling	2	http://www.mcmaster.com/#2424k15/=11byla4	\$30
Low Profile Mounted Bearing	4	http://www.mcmaster.com/#7208k52/=11heosw	\$120
	4	https://www.grainger.com/product/DAYTON-Flange-Bearing-3FCN3?functionCode=P2IDP2PCP	\$175
Bike Shock	2	http://www.amazon.com/Bicycle-Suspension-Bumper-Spring-Absorber/dp/B00AO3TDG0/ref=sr_1_3?ie=UTF8&qid=1457914023&sr=8-3&keywords=Mountain+Bike+Shocks	\$37
1.5"x1.5"x4' Steel Square Tube (needs machining)	1	http://www.metalsdepot.com/products/hrsteel2.phtml?page=sgtube (Stock No.: T111216)	\$15
Bike Shock Mounts	4	http://www.amazon.com/Shepherd-Hardware-9396-Polypropylene-Capacity/dp/B00004Y0GL/ref=sr_1_1?ie=UTF8&qid=1461912197&sr=8-1&keywords=rigid+casters	\$18

3.0 Cut Sheet

While the goal of this wheelchair is to minimize the use of custom made parts, there are a few custom parts that we found were necessary for the assembly to work. The dimensioned drawings for each of these custom parts are shown in pages 6 to 10. The following paragraphs further explain the procedures and tools we used to create each part along with possible alternatives.

Cutting the Gridbeam to Length

While Gridbeam serves as a wonderful prototyping material, it does not arrive precut. To cut the pieces to length we used a Chop Saw because it's relatively cheap, quick, and does not need special maintenance. After making the cuts we strongly recommend using a hand file to round the corners because the saw leaves sharp edges.

Creating the Motor Mounts





Unlike the Gridbeam, the beams that are used to mount the motors need holes drilled. For this operation we recommend using a drill press. We recommend using a square and ruler to carefully mark out the holes to be drilled and use a center punch to start each hole. The more accurate the hole placement is the easier the final assembly will be. If you are unsure of your accuracy, drilling slightly oversized holes will allow some play in fitting and make it easier to put together. An alternative to the drill press is the hand drill, although it's not recommended as it's harder to get a clean hole.

Creating the Square Plates

The square metal plates are used to transfer power from the motor to the wheel by fixing it to the wheel hub. They are square because metal stock comes in rectangles and are easier to cut at right angles. The corners can be rounded for aesthetics but that is not necessary. The most important part is that the center hole and four outer holes are cut very precisely and cleanly. The hole in the center is to go around the driveshaft and needs a keyway cut. This is easily done with a keyway broach, a common tool for cutting keyways. The metal plate is fixed to the hub of the wheel you purchased. Keep in mind that the location of the holes on this part depend on the wheel hub you use. This plate only works with hubs that have a flat lip where you can drill holes.

Drive Shaft

This piece is probably the hardest part of the project. With access to a machine shop this piece is very easy to make. You take a piece of round stock and use a lathe to turn down the piece, then use a die to create the thread at the very end. The keyway slots can easily be cut on a mill using a slot cutting bit. The issue comes with the fact that not many people have open access to a machine shop. If this is the case, your best bet is to take the drawing to a local machine shop. Since the procedure isn't complicated, a competent machinist should not spend over an hour making a piece. A reasonable rate would be \$50 or less per shaft.

Tool	Description	Approximate Cost	Alternatives
Chop Saw 	Quick and easy way of cutting metal. Used for cutting the Gribbeam to length. Warning: Chop saw creates a lot of sparks. Make sure to wear proper protective gear.	\$100 - \$500	Band Saw Table Saw Grinder Hacksaw (slow) Plasma Cutter (\$\$)
Drill Press 	Best way to cut holes in metal. Recommend using cutting oil to improve quality of cuts and drill bit life. Center punch all holes to ensure correct location. Warning: Drilling big holes (>1/2") is dangerous at high speeds. Use a variable speed press for large holes.	Press: \$200 - \$1000 Bits: \$20	Hand Drill Milling Machine
Hand Drill	Cuts holes. Needed for cutting holes in the wheel hub. Can be used as an alternative to the drill press.	\$15 - \$90	
Slot Milling Cutter 	These bits are used to create a keyway on a shaft. It is used in a mill to cut a slot in the shaft.	\$15	Purchase round stock with a keyway already cut.
Lathe 	Lathes are the best way to turn down the diameter of a metal rod. This is not something that is common and affordable to consumers but available in almost every machine shop.	\$1000 - \$10,000	See paragraph on the driveshaft fabrication.
Keyway Broach and Arbor Press 	Broaches are the easiest way to create a keyway slot in a hole. The guide bushing is inserted into the hole and the broach is pushed through with the press. As you push the teeth gradually cut a square keyway into the hole.	Broach + Guide: \$50 Arbor Press: \$40 - \$100	Use a clamp, vice, or drill press to push the broach through. Using tools other than an arbor press could damage the broach if force is not applied evenly.
Circular Saw	Used to cut wood. We used this to cut the wooden sheet where the person would sit.	\$50 - \$150	Hand Saw Table Saws
Wrenches	Adjustable and non adjustable wrenches are used to tighten bolts	\$10 each	
Square	Used to ensure right angles. Highly recommended during assembly to make sure beams are tightened square to each other.	\$5	

NOTE: See page 4 for cutting procedures and suggestions, and page 5 for tools used.

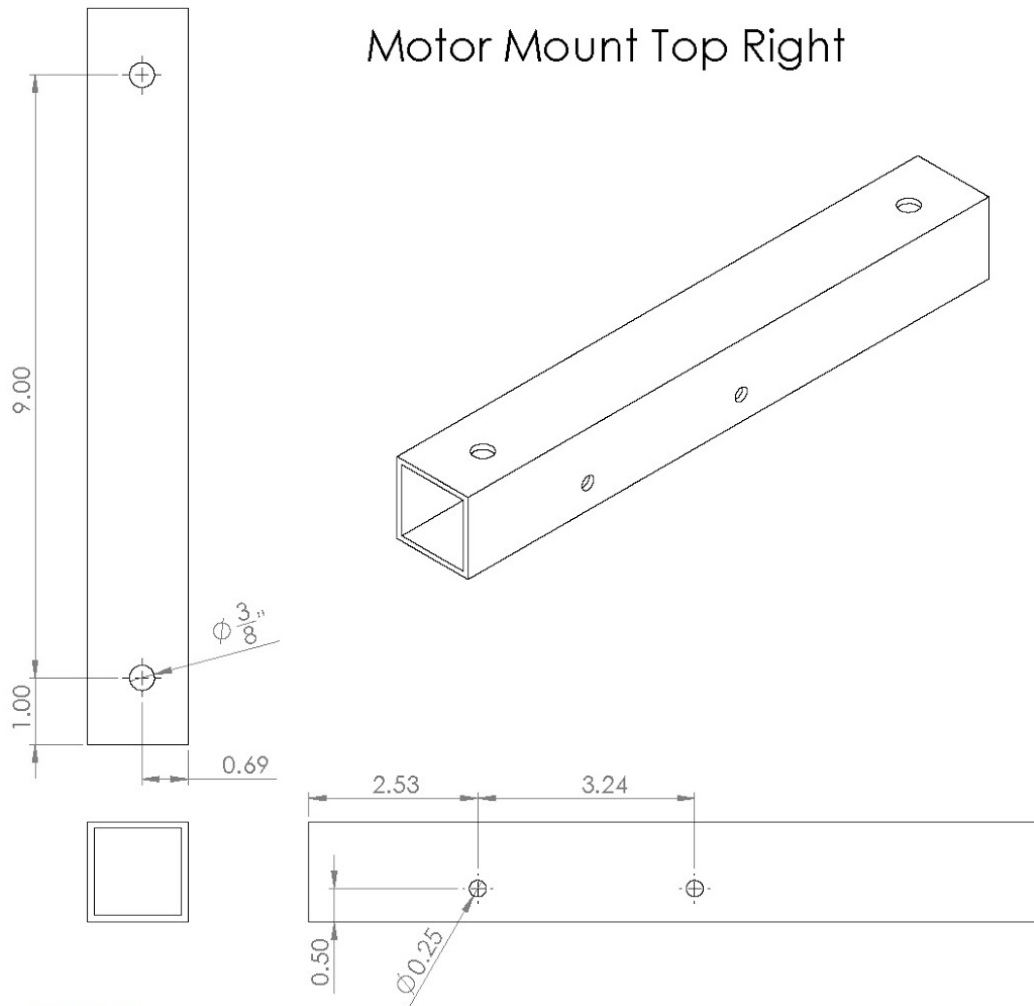

NOTE: 1/4" hole placement may vary depending on motors used.

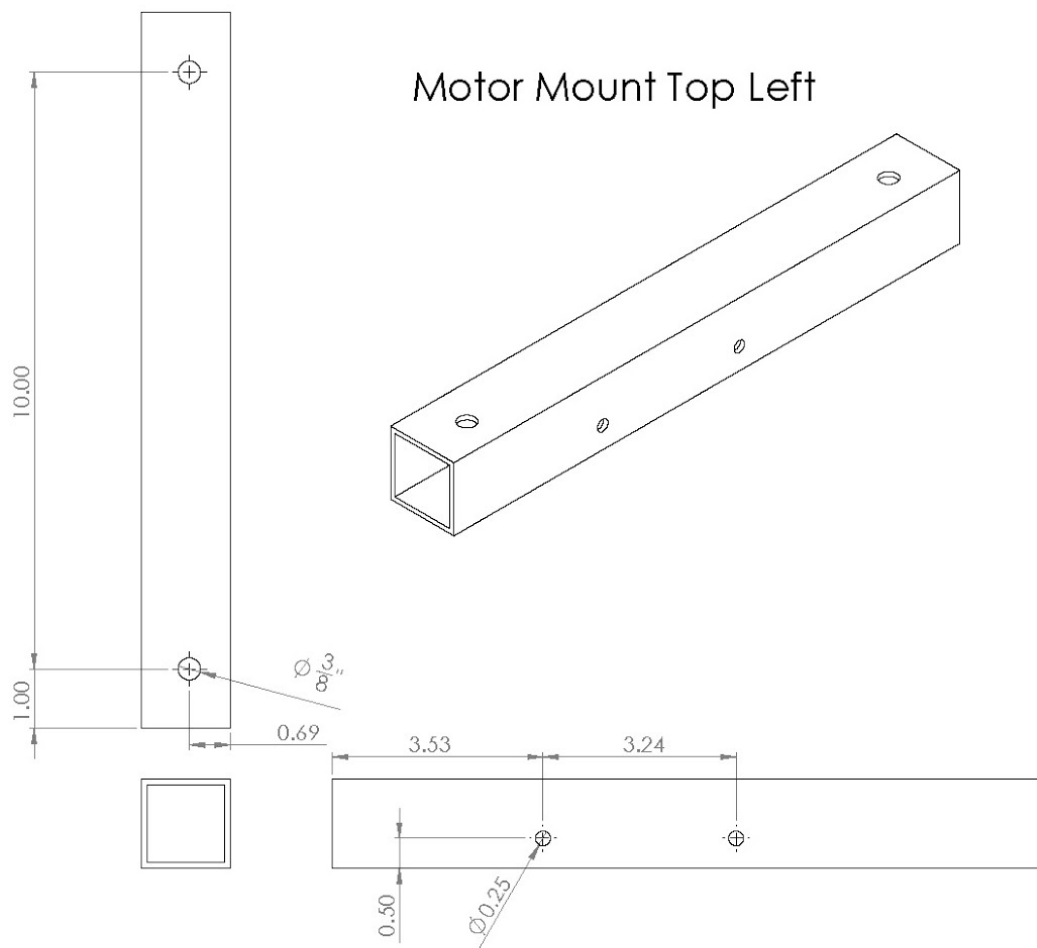

NOTE: 1/4" hole placement may vary depending on motors used.

Motor Mount Bottom Right

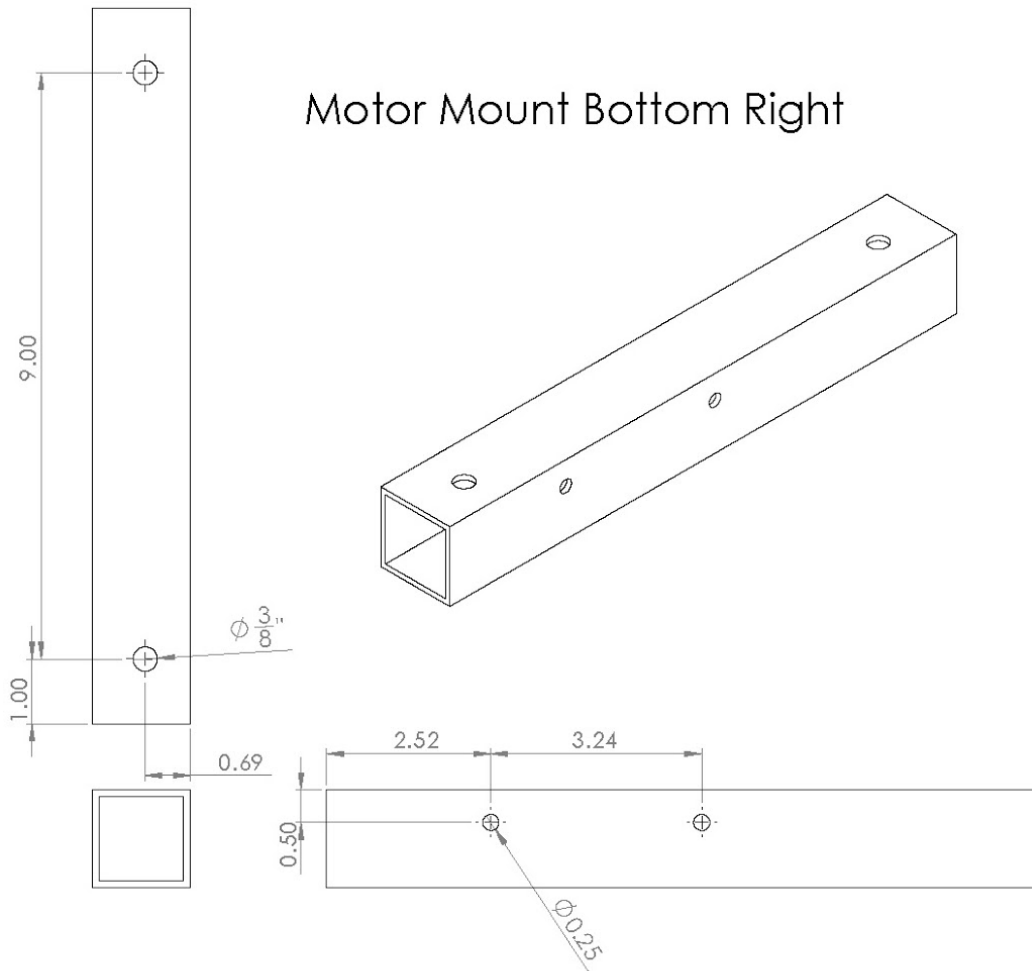

NOTE: 1/4" hole placement may vary depending on motors used.

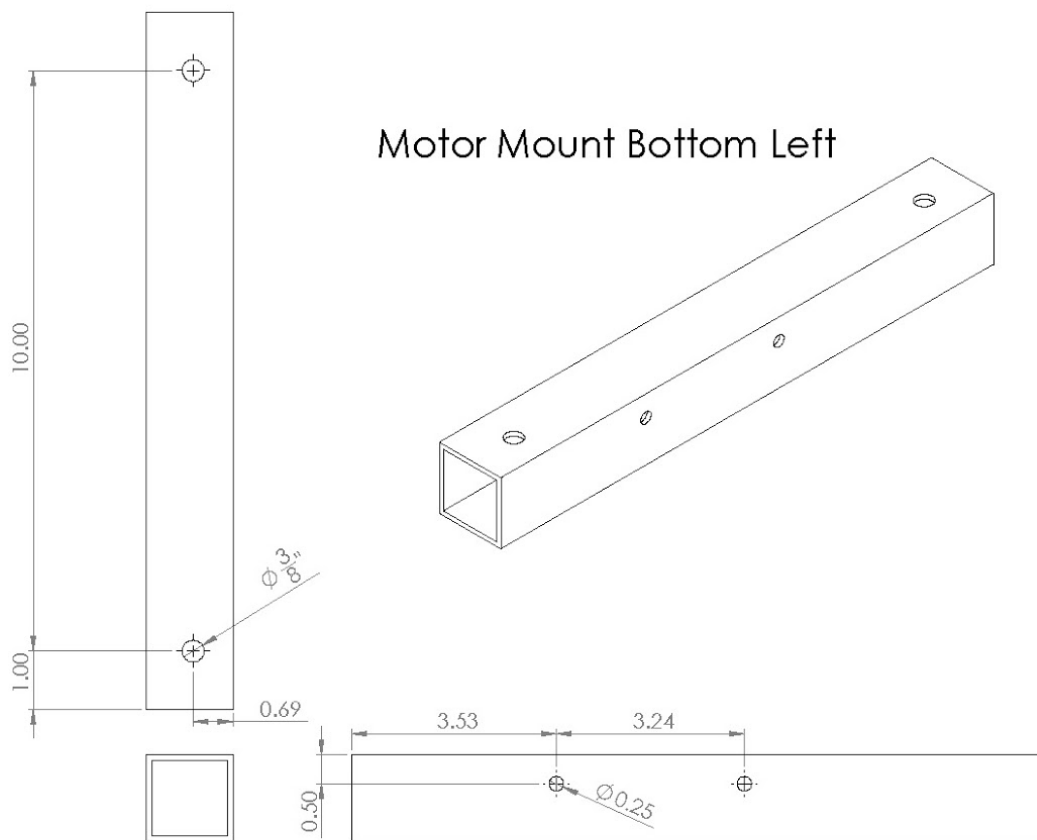

NOTE: 1/4" hole placement may vary depending on motors used.

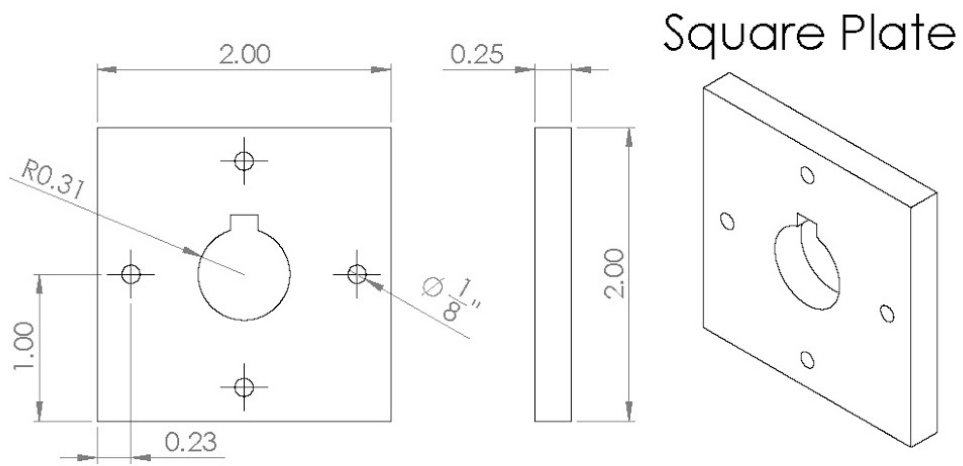
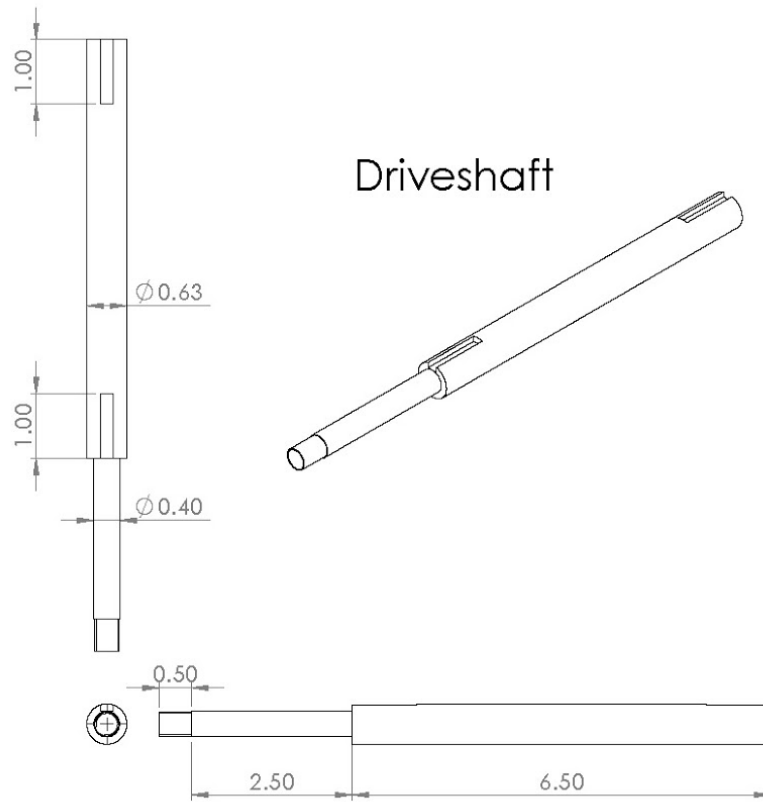

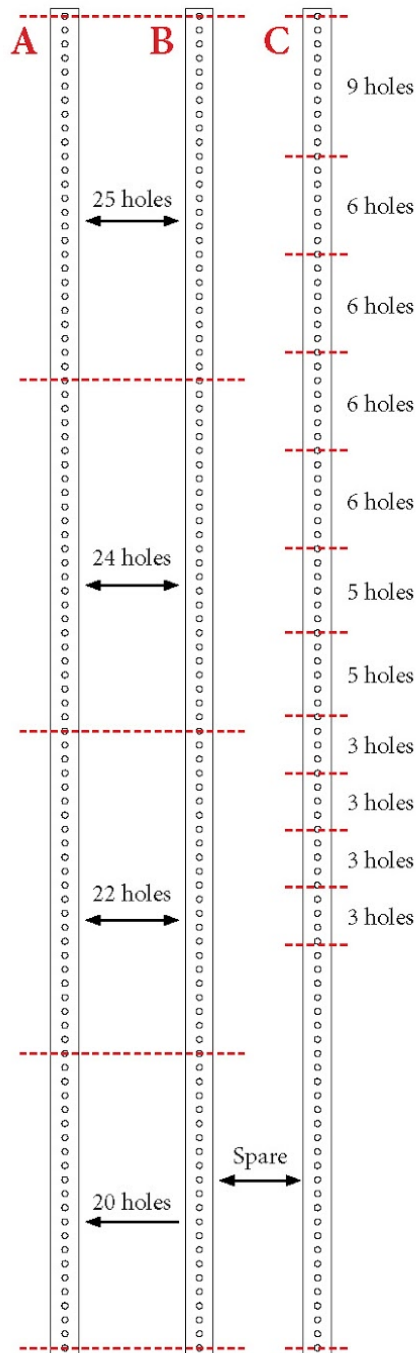

Gridbeam Cuts (for 8' stock)		
# of Holes	Qty	Gridbeam Piece
3	4	C
5	2	C
6	4	C
9	1	C
20	1	A, B
22	2	A, B
24	2	A, B
25	2	A, B

NOTE: All cuts should be made on the center of each hole as shown. Make sure to deburr all cut edges to avoid hassle later. Cutting based on the number of holes ensures the parts will line up during assembly.

4.0 Assembly

4.1 Caster Assembly

Parts Needed:

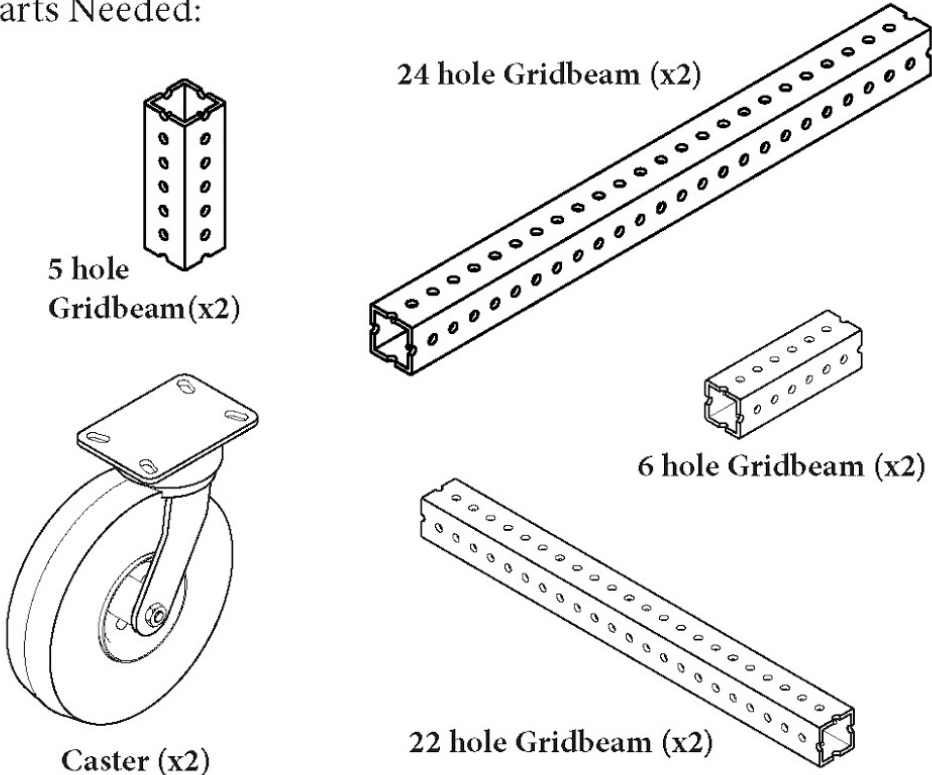

Bolts Needed				
	Qty	Size	Length	Threading
	6	3/8"	4.5"	End
	4	3/8"	7"	End
	4	3/8"	3.5"	End

Nuts Needed		
	Qty	Size
	14	3/8"

Washers Needed	
	Hole Size
	3/8"

- 1** Line up the 22 hole Gridbeam with the two casters. Use washers so bolts don't slide through the caster holes.

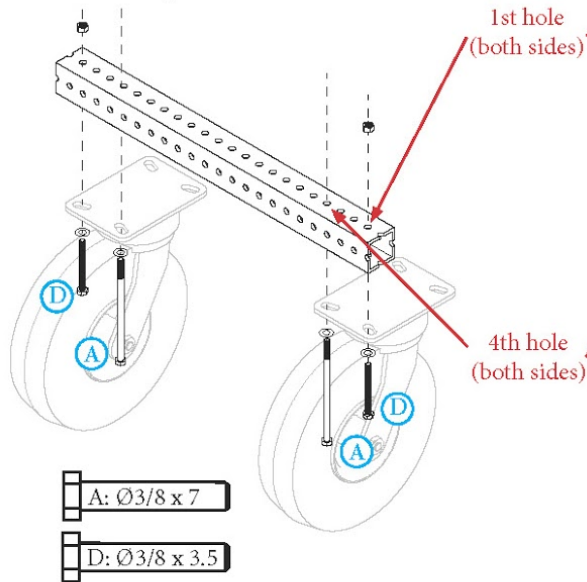

- 2** Line up the second 22 hole Gridbeam and make sure to finger tighten nuts on the bolts marked A.

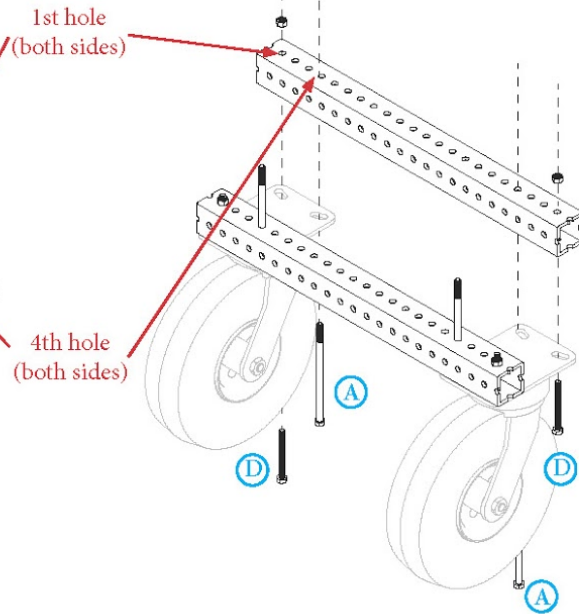

- 3** Insert the 5 hole Gridbeams so they're flush with the forward 22 hole Gridbeam. Tighten the bolts marked C.

C: Ø3/8 x 4.5

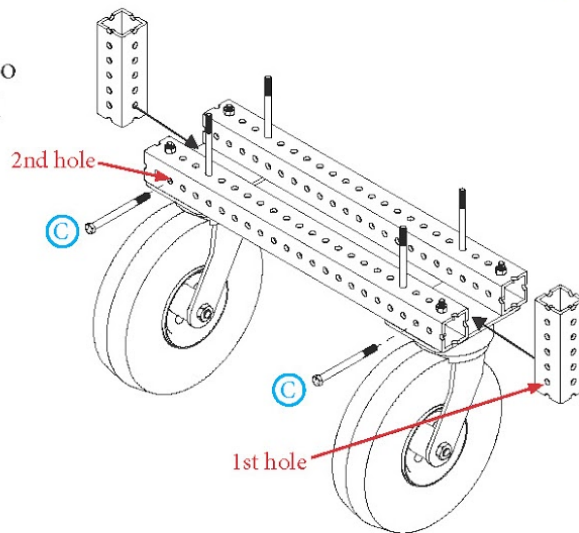

- 4 Place the two 6 hole Gridbeam pieces to create the Tri-Joints as shown.

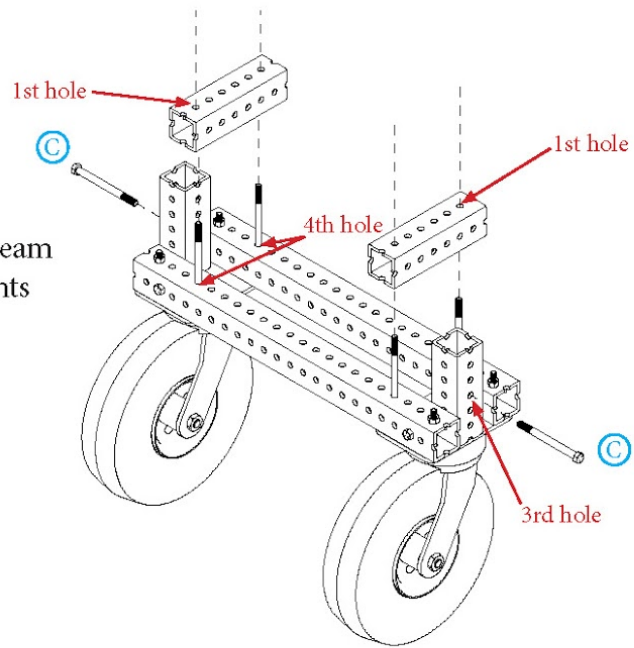
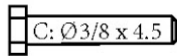

- 5 Tighten all bolts to make sure the Tri-Joint is rigid and strong.

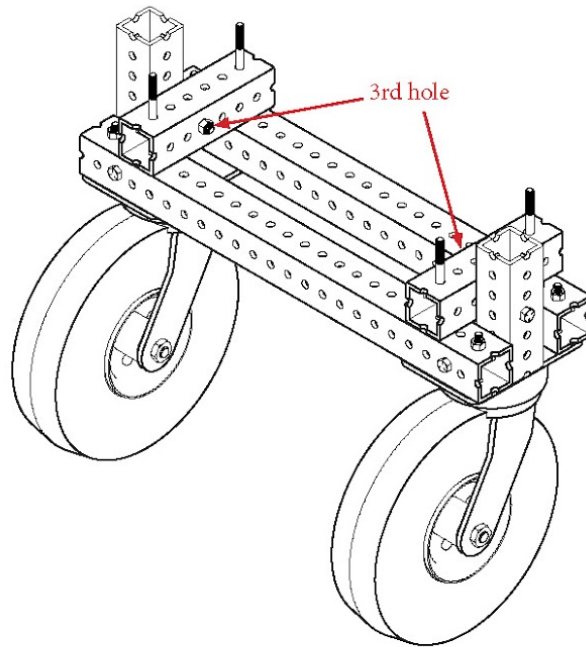

- 6 Place the two 24 hole Gridbeam pieces on the 6 hole Gridbeam pieces. Tighten all bolts and complete the Tri-Joint.

C: $\text{Ø}3/8 \times 4.5$

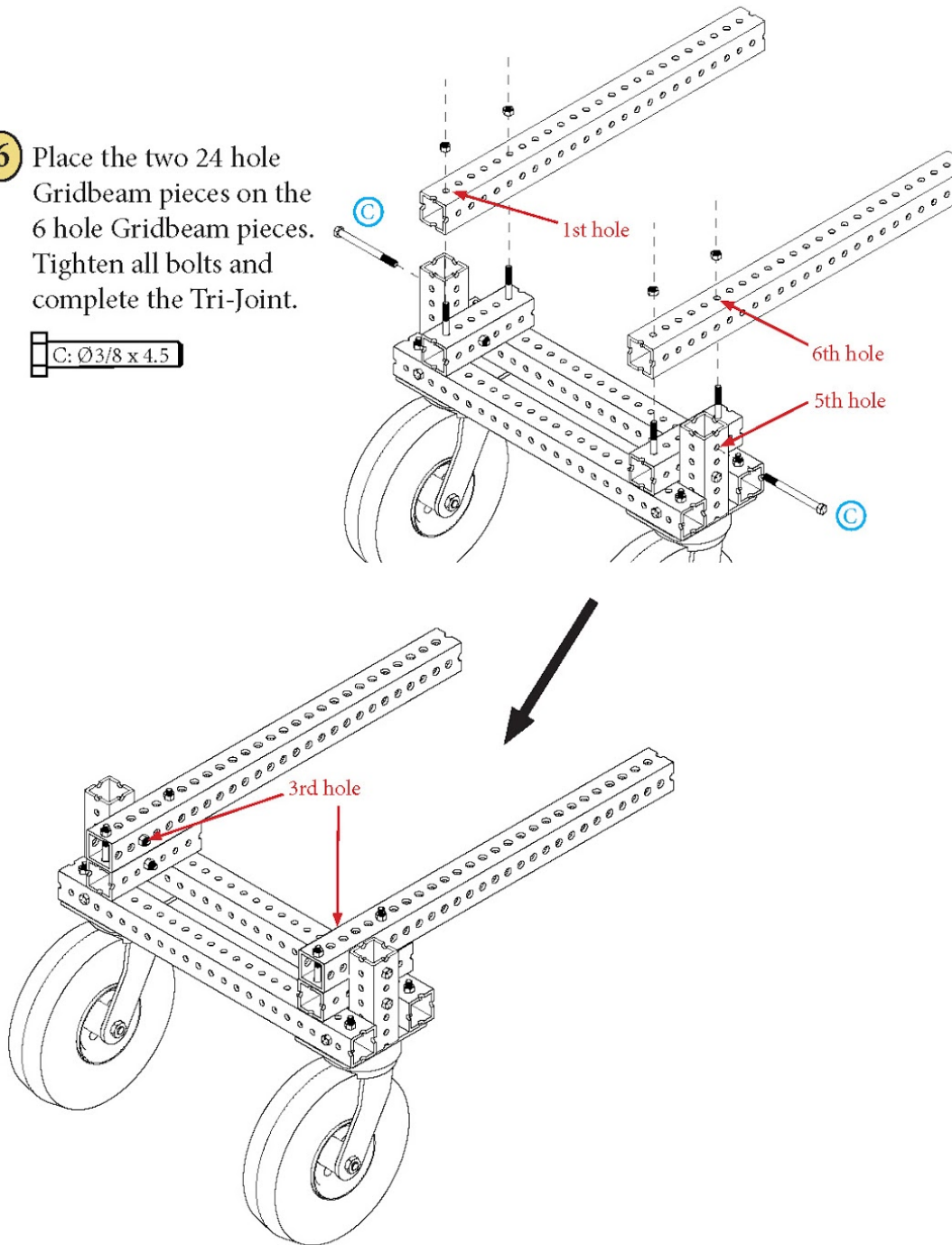

4.2 Motor Assembly

Parts Needed:

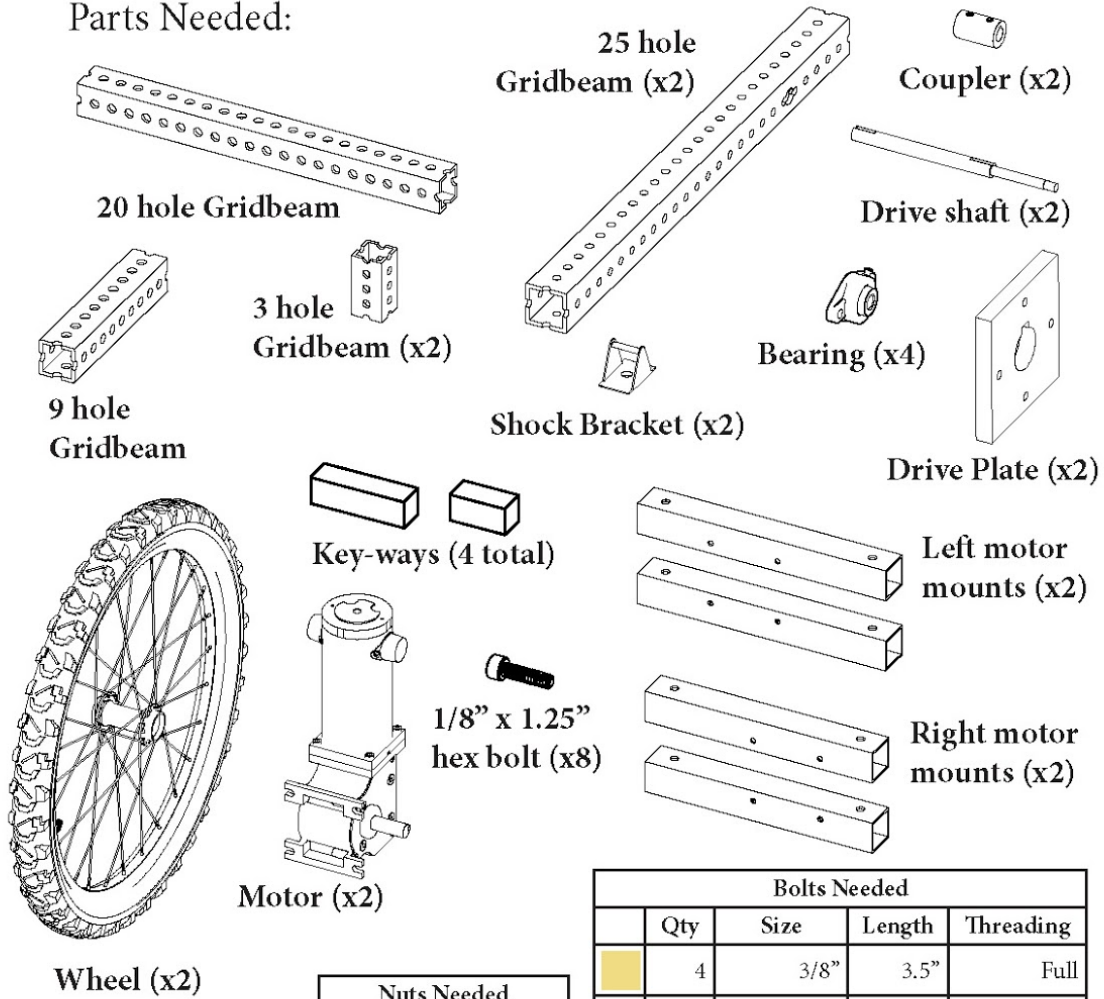

Washers Needed	
Qty	Hole Size
As needed	3/8"

Nuts Needed	
Qty	Size
17	3/8"
8	1/4"
8	6-32"

Bolts Needed				
	Qty	Size	Length	Threading
	4	3/8"	3.5"	Full
	4	3/8"	6.5"	End
	7	3/8"	4.5"	End
	8	1/4"	2.5"	Full
	2	3/8"	3"	End

- 1 Put the drive shaft through the square plate using the smaller key-way to lineup the parts.

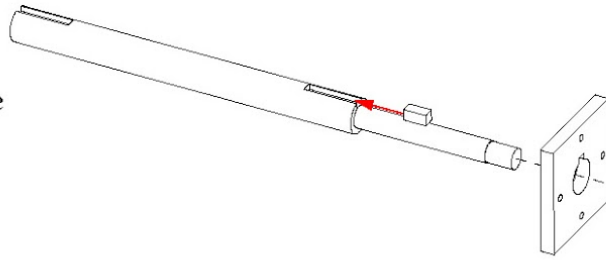

- 2 Put the drive shaft assembly through the wheel hub.
NOTE: Hub spokes omitted for clarity.

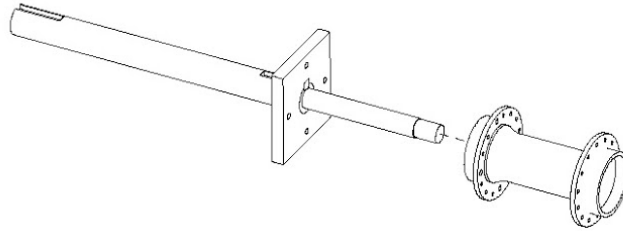

- 3 Use the 6-32 hex bolts and lock-nuts to attach the square plate to the wheel hub. Thread on the hex nut to the end of the drive shaft.

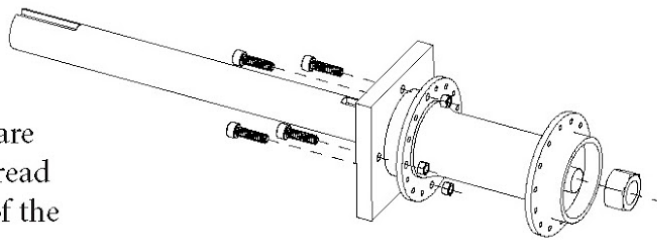

- 4 Repeat steps 1 to 4 for the other drive shaft assembly. Make sure to tighten all bolts with a wrench.

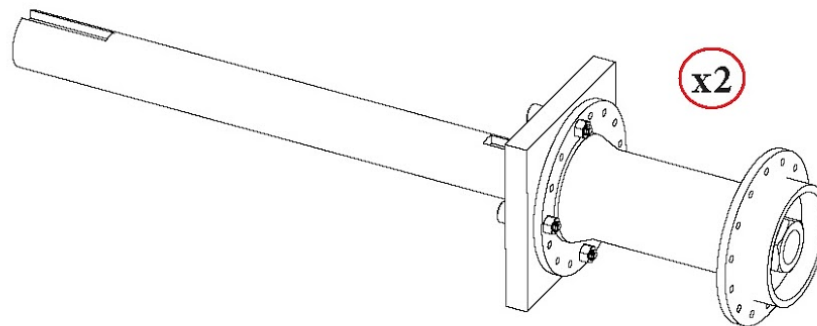

- 5 Mount the bearings on the 25 hole Gridbeam bar but don't completely tighten the bolts. Do this a second time to complete the other wheel hub assembly.

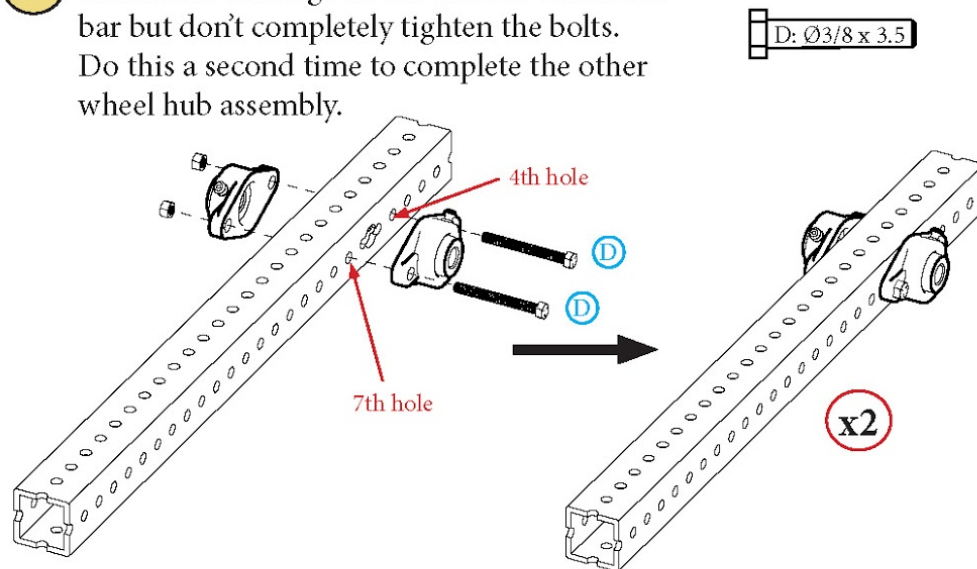

- 6 Bring the two wheel hub beams together and line up the 20 hole Gridbeam. Finger tighten the bolts.

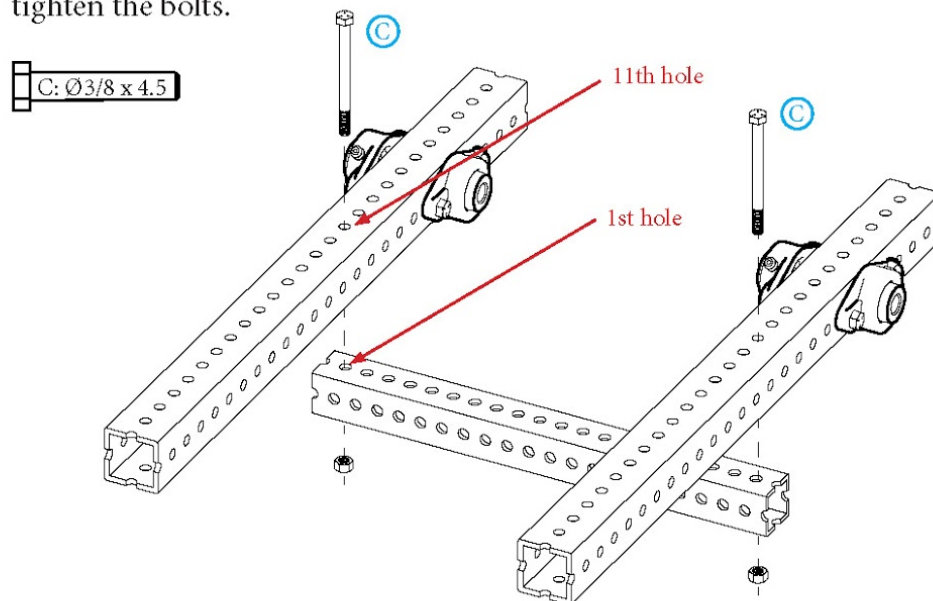

- 7 Place the two 3 hole Gridbeam pieces to create two Tri-Joints. Finger tighten the bolts.

 C: $\text{Ø}3/8 \times 4.5$ x4

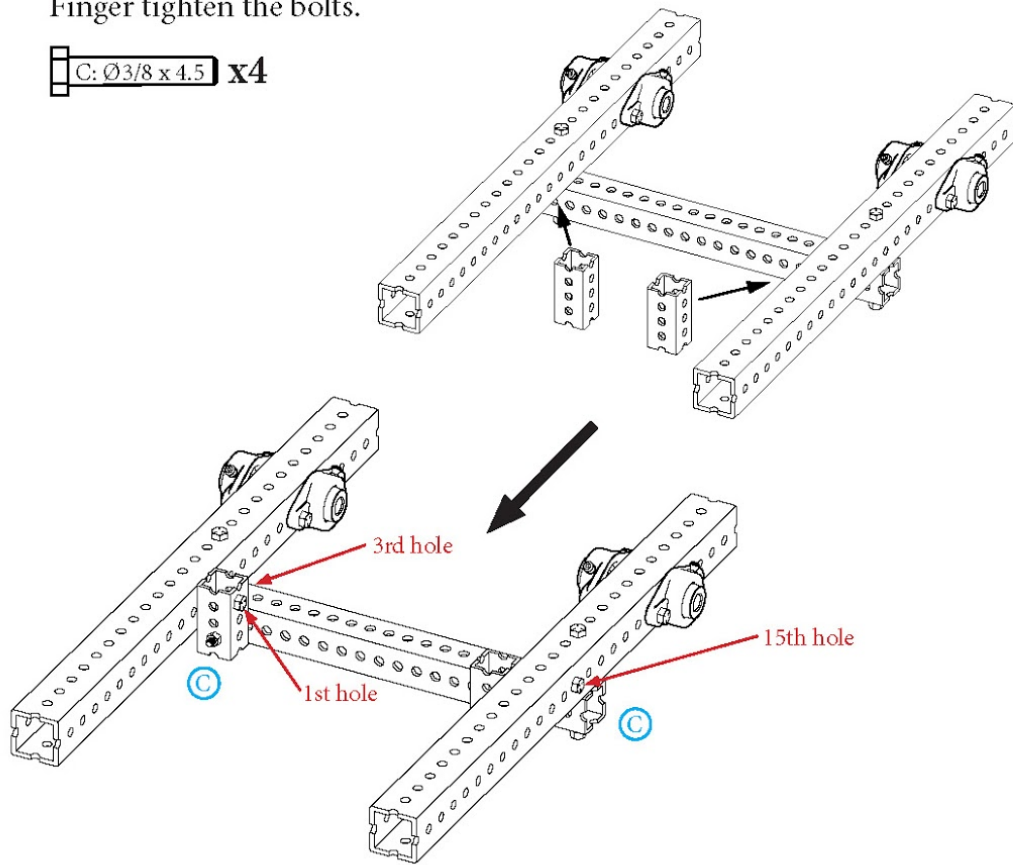

- 8 Use a triangle to make sure all connections are square. Tighten all bolts using a wrench.

- 9** Line up the 9 hole Gridbeam piece and finger tighten the bolt.

C: $\text{Ø}3/8 \times 4.5$

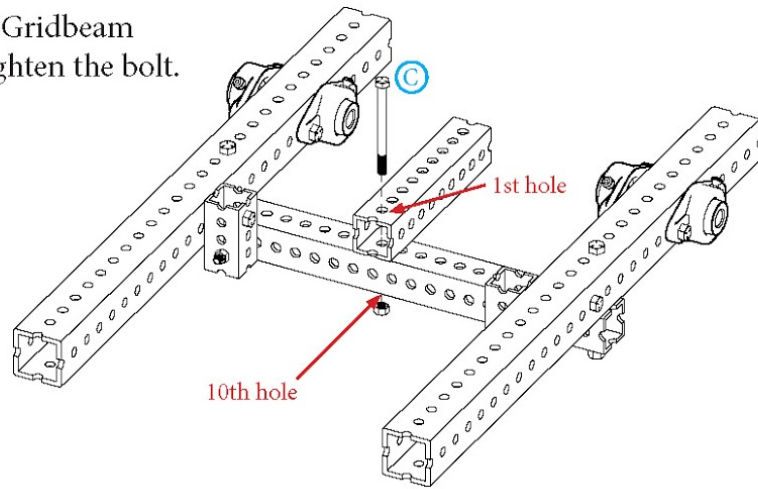

- 10** Attach the motor mounts to both sides of the assembly. Finger tighten the bolts.

B: $\text{Ø}3/8 \times 6.5$ x4

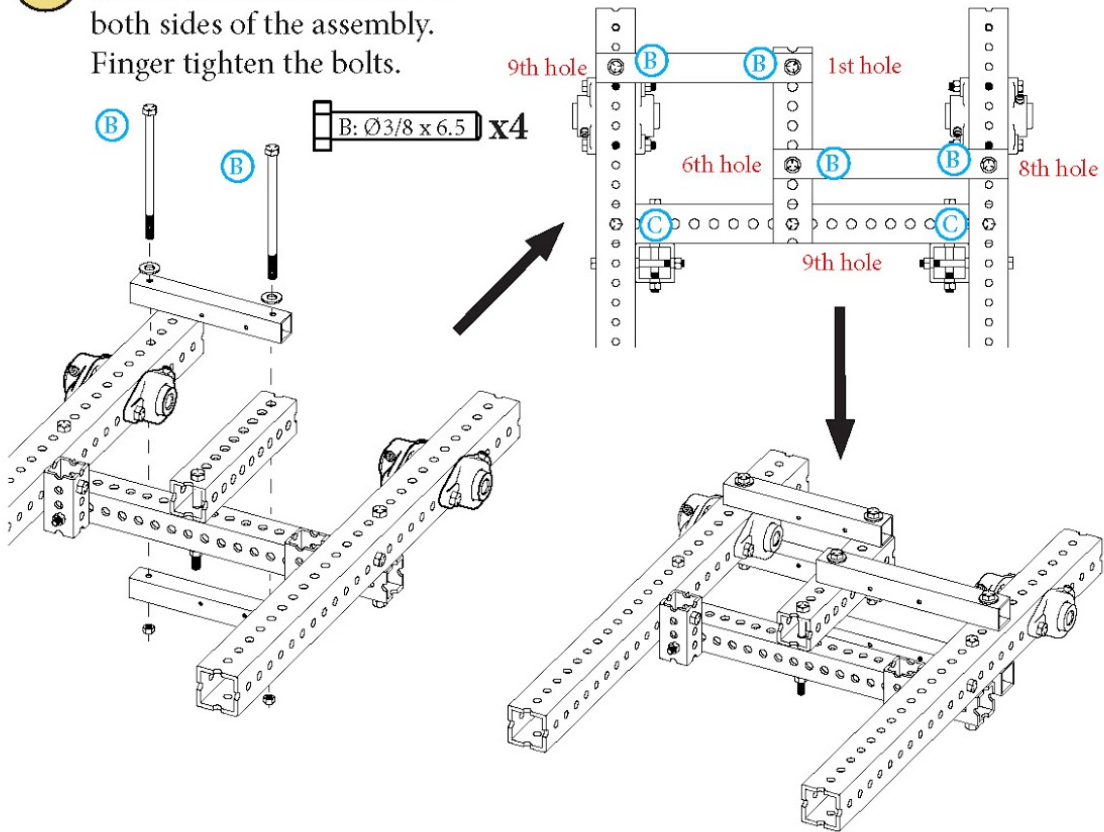

- 11** Line the couplers up with the motor shafts. Make sure the key-way reaches the end of the coupler.

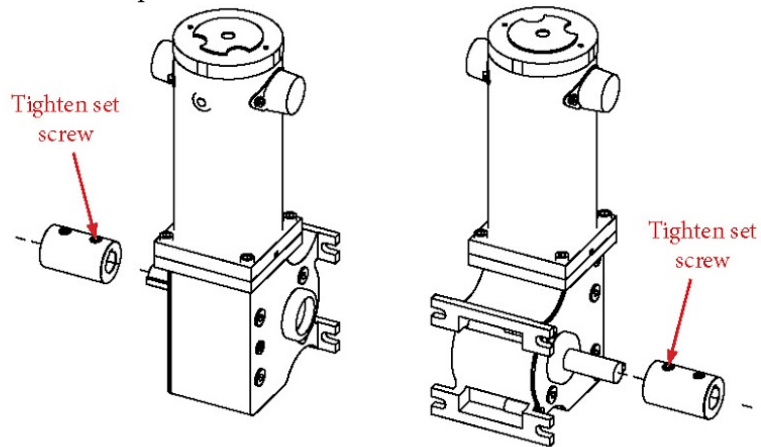

- 12** Slide the motors into the space so the couplers line up with the bearing holes. Use the bolts as guides and tighten so the motors won't move.

 F: $\text{Ø}1/4 \times 2.5$ x8

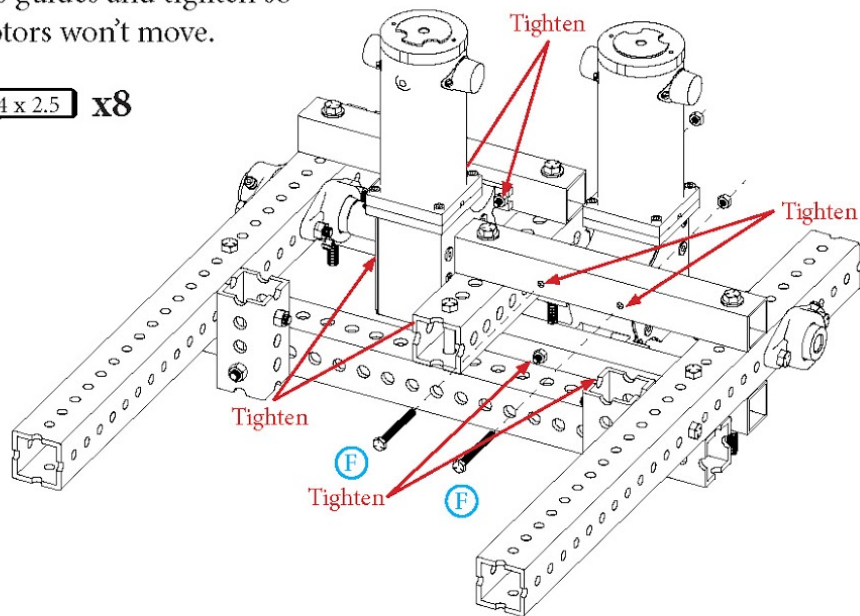

- 13** Make sure all joints are square and tighten all bolts with a wrench. Install the shock brackets.

E: $\text{Ø}3/8 \times 3$

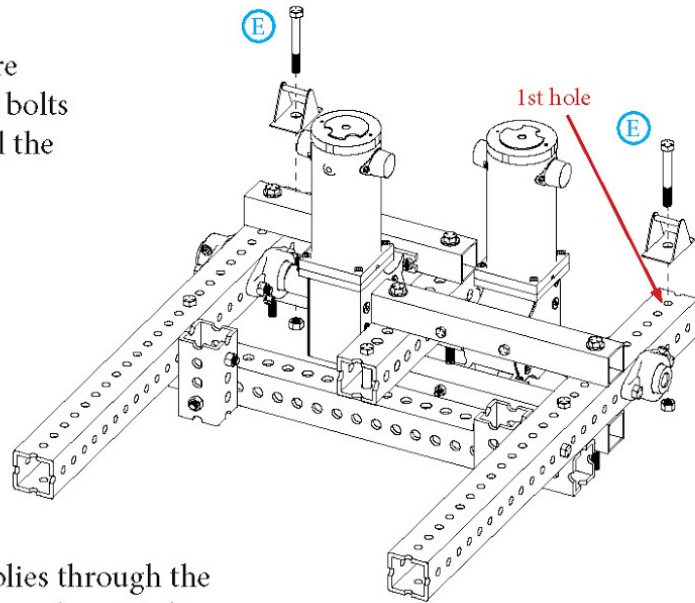

- 14** Slide the wheel assemblies through the bearings and into the couplers. Tighten all set screws and bolts and make sure the wheel engages the motor.

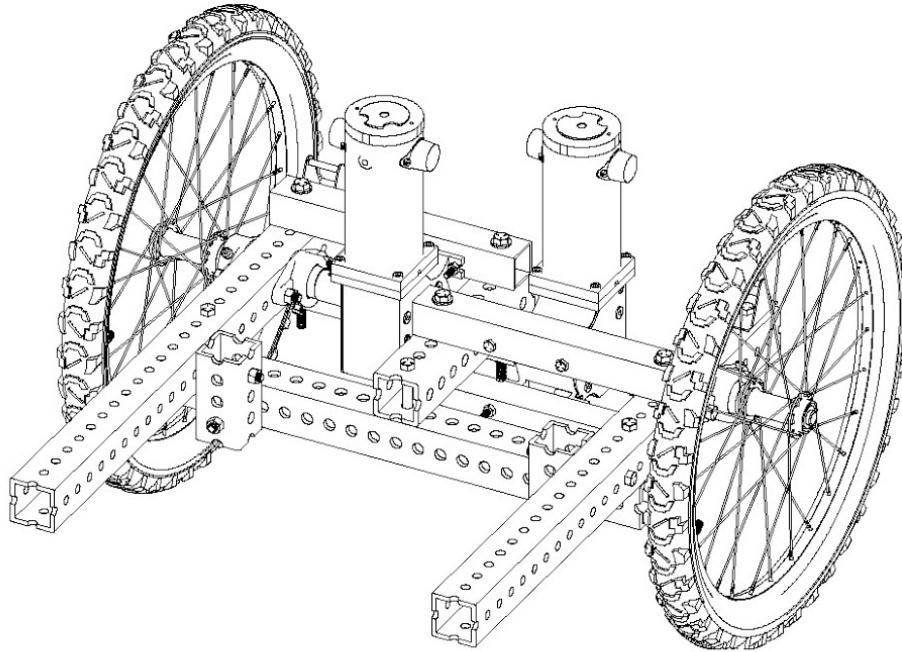

4.3 Final Assembly

Parts Needed:



Shock Bracket (x2)



Shock (x2)

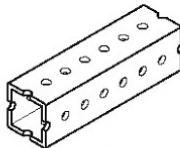

6 hole Gridbeam (x2)

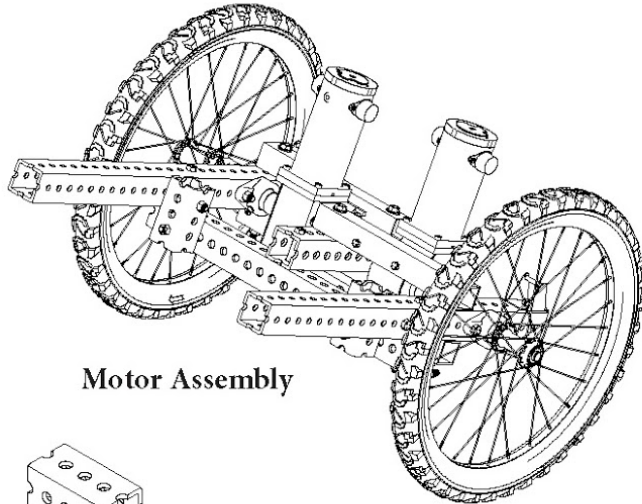

Motor Assembly

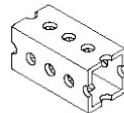

3 hole Gridbeam (x2)

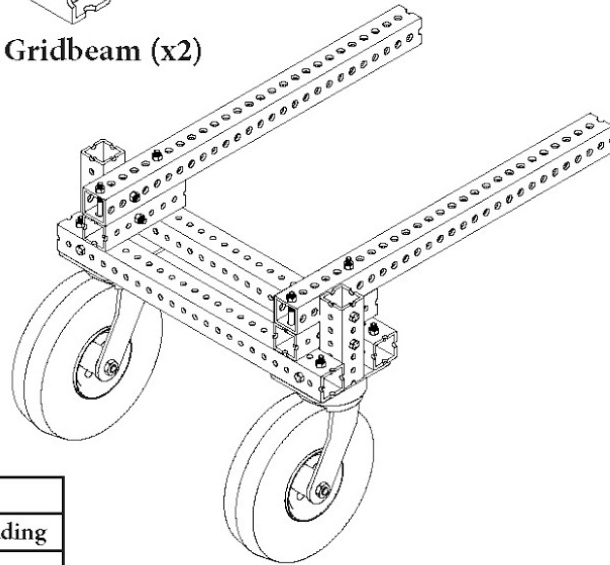

Caster Assembly

Nuts Needed		
Qty	Size	
10	3/8"	

Bolts Needed				
Qty	Size	Length	Threading	
2	3/8"	3"	End	
8	3/8"	4.5"	End	

- 1 Place the 6 hole Gridbeam pieces on either side of the caster assembly.

C: $\text{Ø}3/8 \times 4.5$

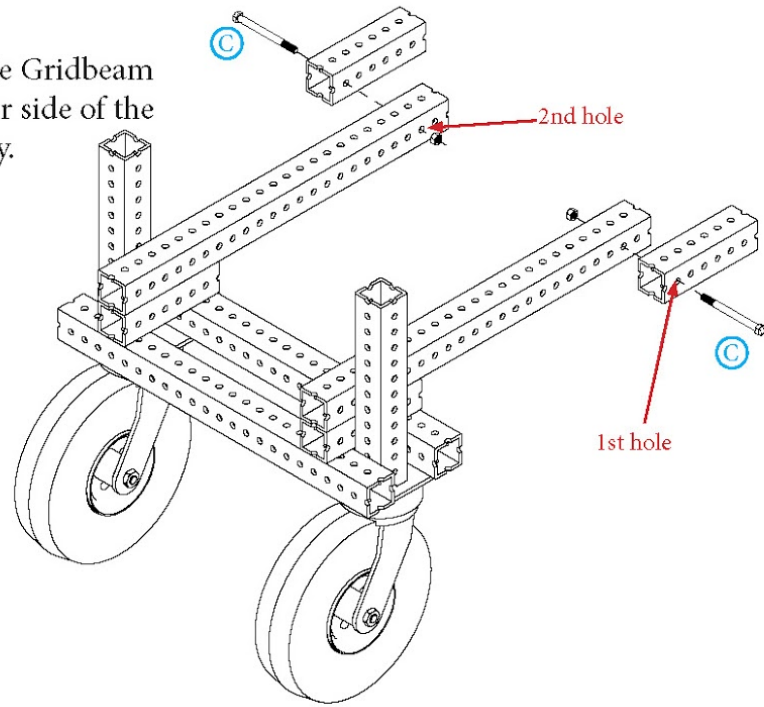

- 2 Line the shock brackets up on the two 6 hole Gridbeam pieces. Use two 3 hole Gridbeam pieces to strengthen the joint.

NOTE: Bracket placement may vary depending on shock size and length.

C: $\text{Ø}3/8 \times 4.5$

E: $\text{Ø}3/8 \times 3$

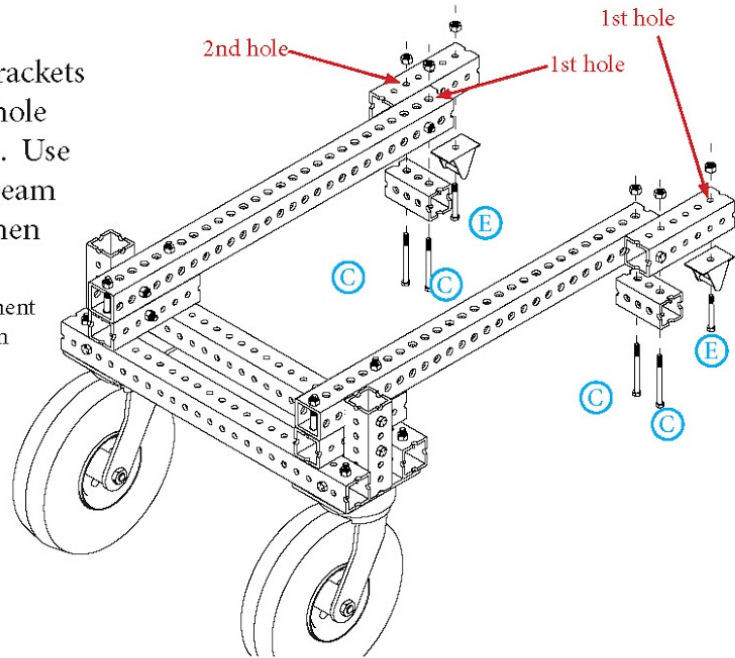

- 3 Line the caster assembly and motor assembly together.

C: $\text{Ø}3/8 \times 4.5$

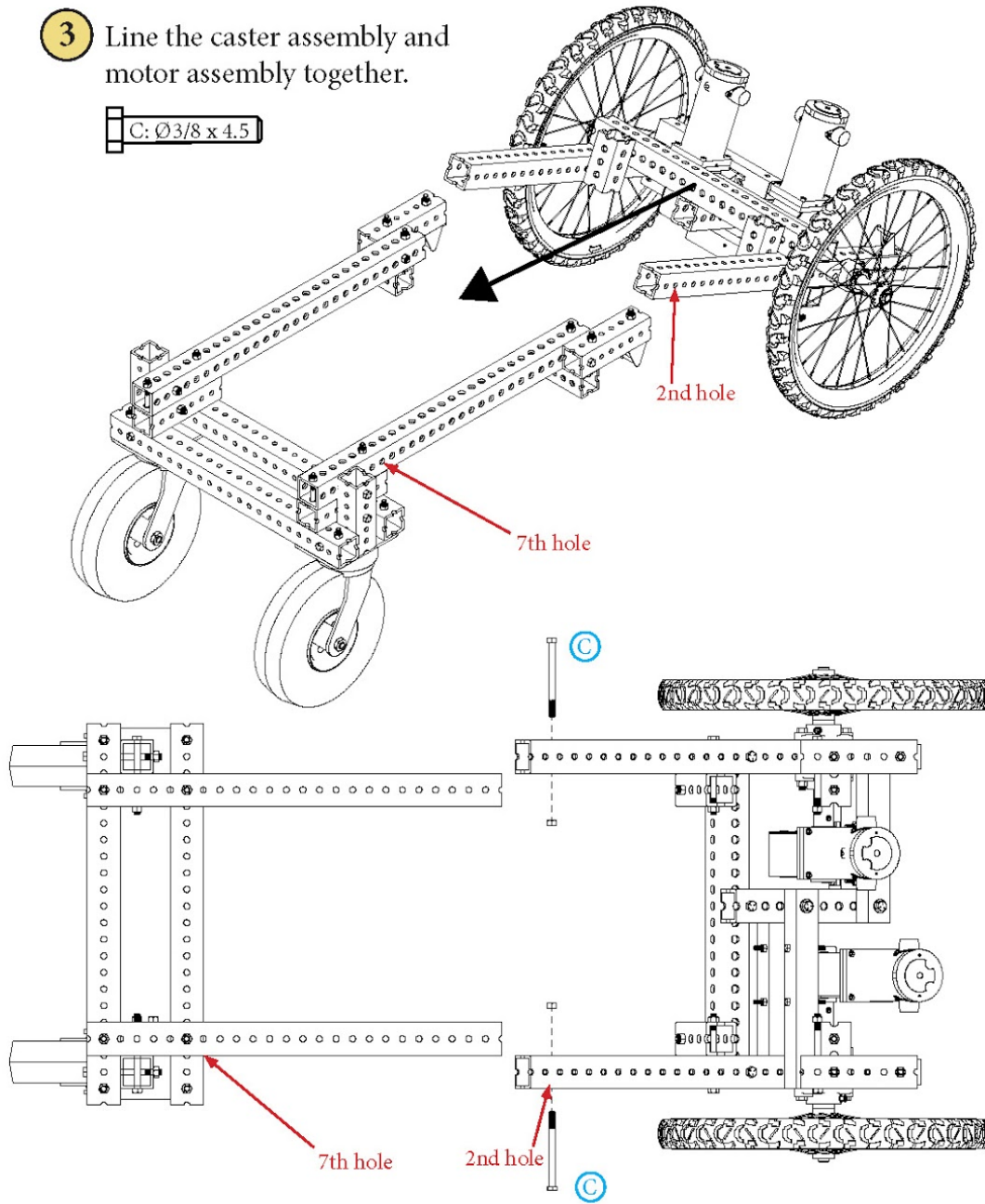

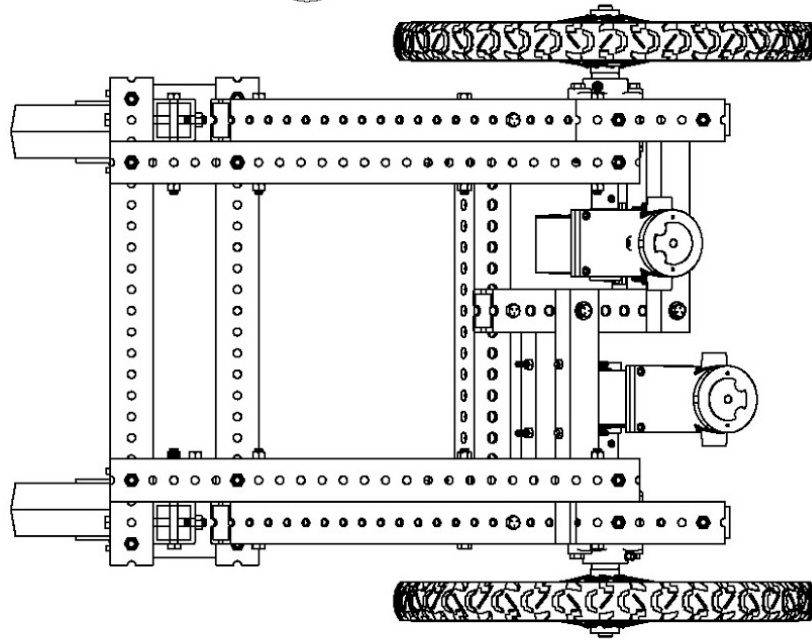
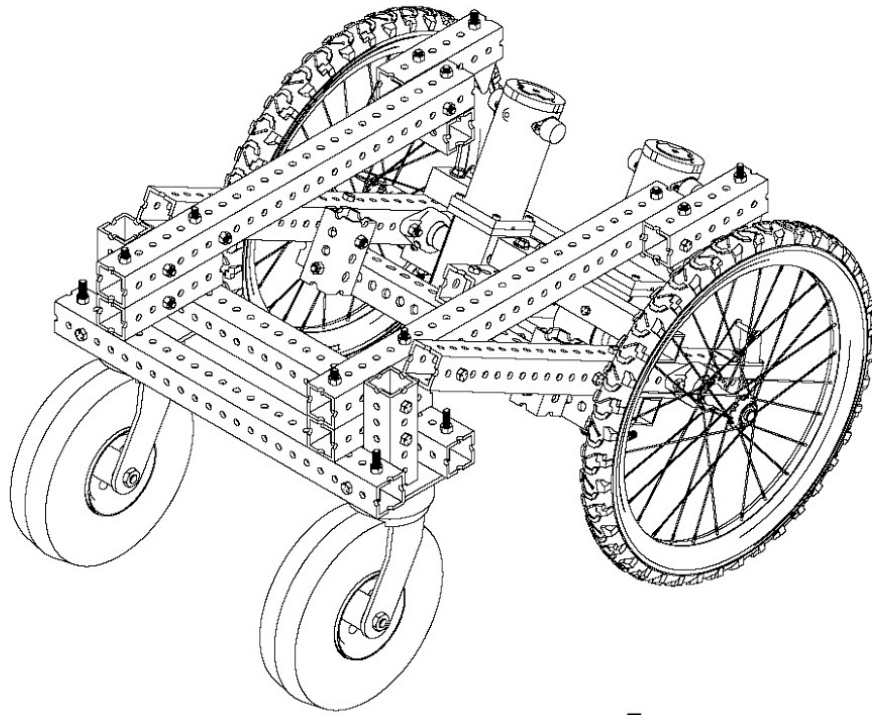

- 4 Install the shocks using the shock brackets on the frame. Install the chair platform.

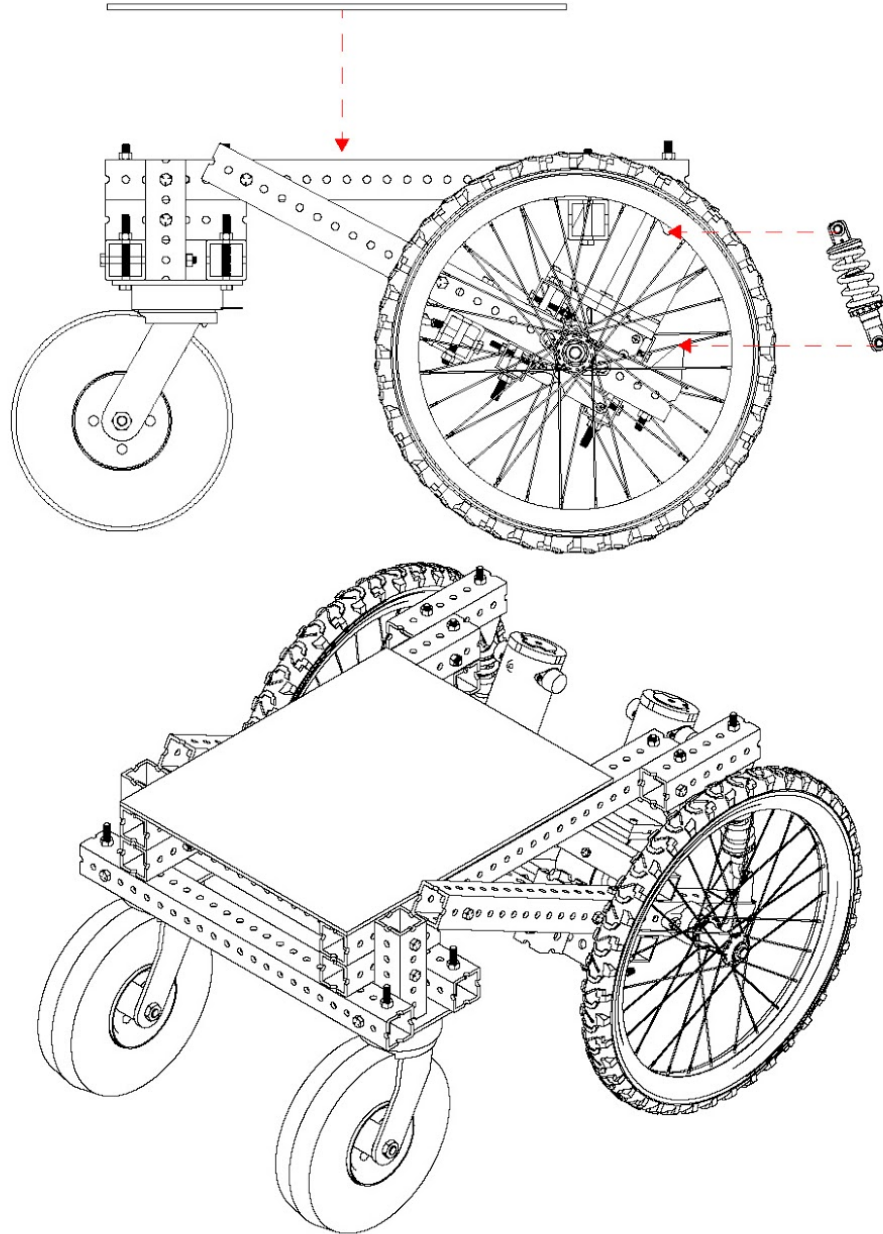

5.0 Design Recommendations

After building the prototype detailed in the previous pages, we've determined the following improvements can be made to better the design. We've also provided a list of potential upgrades and add ons for the base, along with suggestions for the controller and batteries.

Decrease Body Width

As stated in the preface, the body itself is a little wide (by ~4"). The following can decrease this dimension:

- Bring the caster wheels in by one hole and cut all cross member beams down by one hole. Smaller casters can also be used to decrease the distance further.
Approximate width decrease: ~1"
- Thinner bearings can also be chosen to allow the wheels to be brought in on either side. This will also allow the motors on the inside to be brought closer to the swing arm.
Approximate width decrease: ~1"
- Cutting down the motor shaft will allow the drive shaft to be brought in further.
Approximate width decrease: ~1/2"
- If the previous steps are performed, the motor swing arm and caster swing arm positions can be swapped. The result would be the caster swing arms straddling the motor swing arms instead of the reverse.
Approximate width decrease: ~2"

Decrease Weight





The Gridbeam used is ideal for initial prototyping, however it's weight and dimensions aren't ideal for a final product. Other options are to use stock square tubing such as that used for the motor mounts. Holes can be drilled using a drill press in the joint locations used in the Gridbeam. This will also decrease the overall cost of the chair since the stock is more available than Gridbeam. Smaller Gridbeam (i.e. 1" x 1") can also be used.

Other Changes

Other changes can be made to better suit user preferences. Smaller casters can be used to decrease the seated height of the user. The motor cage in the back can also be redesigned to better save space. The springs are also fairly stiff, so a lower spring load rated spring (less than 500 lbs/in) can provide a dampened ride. The plans for the chair aren't meant to be permanent, so design refinement possibilities are endless.

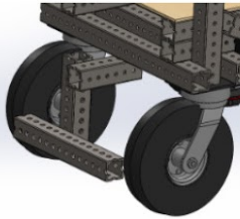
Add-ons and Accessories

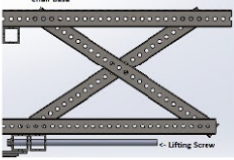
This guide is a combination of tips and instructions with the goal that you, the reader, will be equipped with all the information needed to build your own chair. The hope is that this chair will evolve and change with the needs of the user and the ideas of the builder. Our group has designed just the base of the chair and it's now up to you to make it your own. Here is a short list of ideas that we have considered but not yet refined. We hope this list will give you ideas that excite you and motivate your creativity.

<p>Footrest</p> 	<p>By utilizing extra Gridbeam, a makeshift footrest can be made. Make sure to tighten all bolts and use Tri-Joints if necessary. This can also be made of other material, but make sure it doesn't restrict the motion of the casters.</p>
<p>Chair Mount</p> 	<p>Our design provides a flat platform for any type of chair to be mounted. One idea we had is an office chair since it already incorporates support and armrests and can be found fairly cheaply. Other options include a flat pillow with a wooden backing or a lawn chair. Just make sure the chair is securely attached to the wooden platform.</p>
<p>Lifting Mechanism</p> 	<p>Another feature we were excited about was a lifting mechanism so the chair could access higher counters. This would be incorporated where the wooden platform currently is, and mimics the design of a scissor lift. It would mean adding in a small motor to power a lifting screw that acts like a rack and pinion. Unfortunately we didn't have time to pursue or further develop this option.</p>
<p>Wireless Control</p> 	<p>The USB host shield used can incorporate a wireless controller by using readily available code from online sources. This could provide more comfort for the user in colder operating conditions, or even autonomous operation.</p>
<p>Manual Brakes</p> 	<p>The electric braking on the chair works fairly well, however the addition of manual brakes would further the control the user has over the chair.</p>

Battery Suggestions

The batteries we recommend to use with this wheelchair are two lead acid 12 volt batteries used in series. The batteries can be mounted below the seating platform using two ratcheting tie downs. The recommended battery specifications for each battery are listed below.

Sealed Lead Acid
>50 AH Capacity
Max Dimensions: 6.5" x 10" x 8.5"
AGM or Gel Cell (Spill Proof)

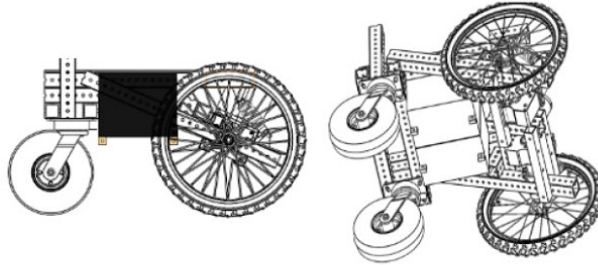

NOTE: Be sure to use two of the same type of battery. Always charge and discharge them evenly or you risk lowering the life of the battery. Use a 24V battery charger and charge them in series. Avoid running the battery to empty. Always replace both batteries at the same time rather than just one.

Controller Suggestions

To control the DC Motors we recommend using an H-Bridge along with a microcontroller. Each motor can then be controlled independently and are able to go forward or backward. In addition to controlling the directions of the motor, the H-Bridge can be cycled on and off using PWM to control speed. A USB host shield can be added to incorporate USB devices such as a joystick.

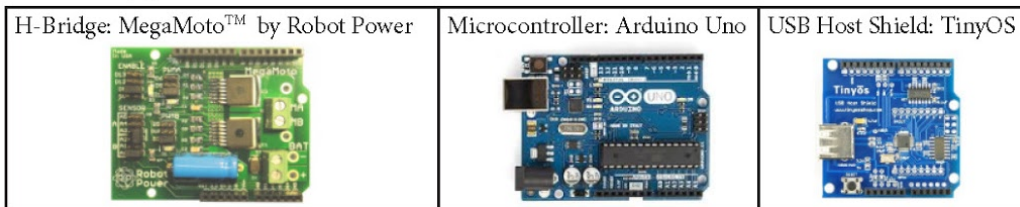

In our prototype we used an Arduino microcontroller in combinations with a MegaMoto™ H-bridge. To incorporate USB devices such as a joystick, we also used a USB host shield. These three boards are designed to stack on top of one another. The configuration of these boards is shown in the block diagram.

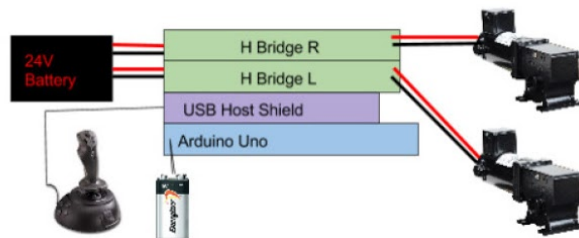

6.0 Maintenance Guide

Maintenance is an important aspect to maintaining optimal performance of your wheelchair and ensuring all the parts have a long life. We feel the following components are the most important for performing maintenance.

Frame

The wheelchair was designed to have a robust frame that would not break down easily. That being said, it is still important to check the frame every so often for any cracks or loose bolts. For most of the bolts, we recommend checking them about once a month to see if any cracks have formed, or to see if they need any tightening. For the two bolts connecting the swing arm assembly to the front caster assembly, we recommend checking them once every two weeks. Since those two bolts are connecting two moving pieces of the frame together, there is a higher chance of those bolts coming loose than any other bolt. With the exception of the two swing arm bolts, it is important to tighten any other loose bolt with a t-square or triangle square to make sure all components of the chair remain aligned. Having critical components like the motors and drive assembly operate while misaligned will greatly decrease their life expectancies and overall chair performance.

Wheels

Knowing when to perform any maintenance on the wheels is as simple as looking down and inspecting them. If your tires appear to be flat, check the sidewall of the tires for their PSI rating and fill them accordingly. If you don't have a pressure gauge to check tire pressure, filling up your tires until there is no deflection when you squeeze them with your fingers should suffice.

Truing your wheels should be done only when your wheels have a visible wobble in them due to a broken, or loose spoke or nipple. If you would like to try your hand at truing the wheels yourself, there is plenty of information with video tutorials on the Internet. If you do not want to true your wheels by yourself, you can simply take your chair to a local bike shop and they will gladly true your wheels for you. However, you may need to walk them through how to remove the wheel from the driveshaft.

Periodically, you will also have to replace the tires or tubes on your wheels. Tires and tubes should be replaced if you experience a flat resulting from a puncture. Tires will also have to be replaced when the treads are all worn down, and there is a flat spot along the tire. An alternative to inflatable tires is filled ones, which would eliminate a risk of puncture. Puncture resistant tread should also suffice.

Bearings

It is important to keep your bearings properly lubricated in order to attain maximum life expectancy. Under lubrication can lead to surface fatigue of the ball bearings and races, while over lubrication can damage seals on the bearing and lead to premature failure. When adding grease, it is important to add slowly, and to stop at the first sight of grease at the seals. Hub City recommends re-lubrication of bearings depending on the operating conditions shown below.

Operating Conditions	Bearing Temperatures	Grease Interval
Clean	32°F to 120°F	6 - 12 Months
	120°F to 150°F	1 - 3 Months
	150°F to 200°F	1 - 4 Weeks
Dirty	32°F to 150°F	1 - 4 Weeks
	150°F to 200°F	Daily - 1 Week
Moisture	32°F to 200°F	Daily - 1 Week

For the grease, Hub City recommends any multi-purpose lithium grease with a NLGI grade of 2. The NLGI grading system is a measure of the consistency of the grease, with grade 2 being compared to the consistency of peanut butter.

Grease	URL	Approx. Cost
Synthetic Multi-Purpose Grease NLGI #2 (14 oz.)	https://www.amsoil.com/shop/by-product/grease/synthetic-multi-purpose-grease-nlgi-2/	\$9
Valvoline VV615 Multi-Purpose Grease (14.1 oz.)	http://www.amazon.com/Valvoline-VV615-Multi-Purpose-Chrysler-European/dp/B000CQ4DIM/ref=sr_1_sc_5?ie=UTF8&qid=1464725463&sr=8-5-spell&keywords=ngli+2+lithium	\$5
CRC SL3150 Super White Multi-Purpose Lithium Grease (14 oz.)	http://www.amazon.com/CRC-SL3150-Multi-Purpose-Lithium-Grease/dp/B000M8O04M/ref=sr_1_4?ie=UTF8&qid=1464725923&sr=8-4&keywords=multi-purpose+lithium+grease	\$7
Sta-Lube General Purpose Lithium Grease (14 oz.)	http://www.amazon.com/Sta-Lube-General-Purpose-Lithium-Grease/dp/B000KKLLQ2/ref=sr_1_17?ie=UTF8&qid=1464726177&sr=8-17&keywords=multi-purpose+lithium+grease	\$8

For the most accurate bearing care, consult the information included in the bearings you purchase.

Closing Remarks

The main goal of our project is to allow anyone to build their own electric powered wheelchair. We hope this guide allows anyone to do just this, removing mobility restrictions for those in wheelchairs.

For more information regarding the status of this guide and other similar projects, visit whimunlimited.com. If you have any ideas for improvements, design changes, etc., feel free to share with us and others.

Sincerely,

